



Ram Trucks (with factory 8" screen and auto climate, excluding Classic models) **2019-up**

Visit MetraOnline.com for more detailed information about the product and up-to-date vehicle specific applications

KIT FEATURES

- ISO DDIN provision
- ISO DIN radio provision with pocket sold separately
- Painted scratch resistant matte black
- Retains factory climate control buttons and adds factory-style hard buttons with laser etched graphics to retain and control functions that are normally lost when removing the factory radio
- Built-in OLED screen displays the visual status of climate functions.
- Retains steering wheel audio controls

KIT COMPONENTS

- (A) Radio trim panel • (B) Radio brackets • (C) Display and button assembly • (D) Pioneer modular radio brackets • (E) #6 x 3/8 Phillips screws (4)
- (F) #8 x 3/8" Phillips screws (4) • (G) Antenna adapter (AD-EU5) (not shown) • (H) Interface and harnessing (not shown)
- (I) Blank outs (2) (not used and not shown) • (J) Interface buttons: blanks (5) and with graphics (5) (not shown)

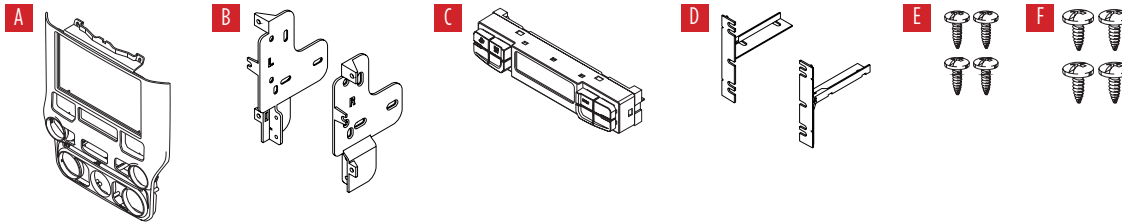

TABLE OF CONTENTS

Dash Disassembly.....	2
Kit Preparation.....	3-4
Kit Assembly	5-8
Axxess Interface Installation	9-19

WIRING & ANTENNA CONNECTIONS

Wiring Harness: Axxess interface built into display screen

Antenna Adapter: Included with kit (AD-EU5)

TOOLS REQUIRED

- Panel removal tool • Phillips screwdriver
- 9/32" socket wrench • T-20 Torx driver

ATTENTION: With the key out of the ignition, disconnect the negative battery terminal before installing this product. Ensure that all installation connections, especially the air bag indicator lights, are plugged in before reconnecting the battery or cycling the ignition to test this product. **NOTE:** Refer also to the instructions included with the aftermarket accessory before installing this device.

DASH DISASSEMBLY

1. Remove the rubber tray liner inside the tray at the top center of the dash, then remove (2) Torx T-20 screws exposed. (Figure A)
2. Unsnap and remove the entire center dash panel. (Figure B)

Continue to Kit Preparation

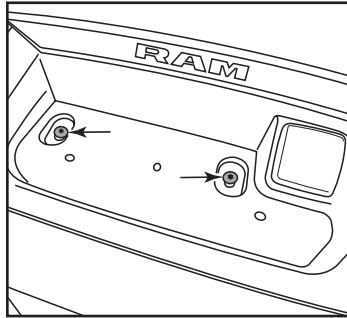

(Figure A)

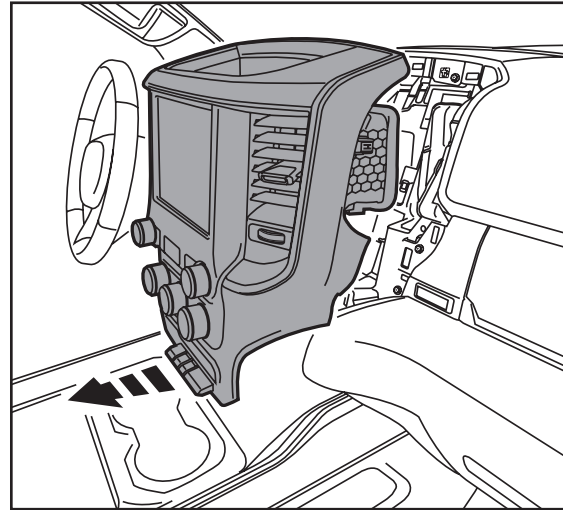

(Figure B)

KIT PREPARATION

From the factory center dash panel:

1. Remove (4) Phillips screws to remove the radio and screen bracket and then the screen assembly. (Figure A)
2. Remove (10) T-10 screws securing the radio/climate control panel, then remove. (Figure B)

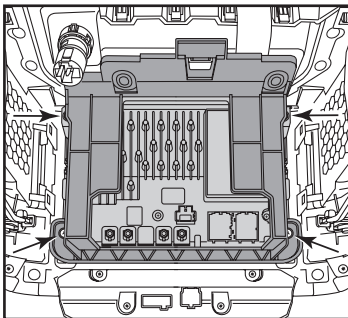

(Figure A)

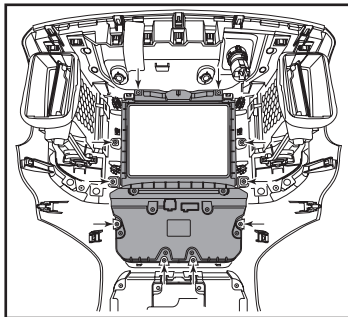

(Figure B)

3. Remove the (8) T-10 screws from the back cover of the radio/climate control assembly. (Figure C)
4. Remove the radio/climate control assembly from the dash panel (Figure D)

Continued on the next page

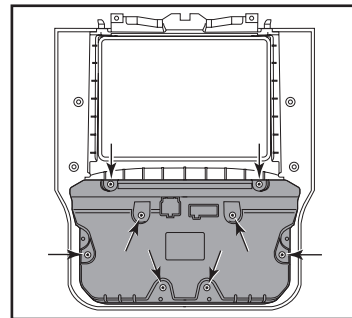

(Figure C)

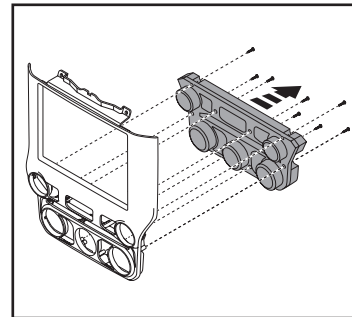

(Figure D)

KIT PREPARATION (CONT.)

To the radio trim panel:

1. Install the climate control assembly into the **radio trim panel** using the (8) factory screws. (Figure A)
2. Place the **radio trim panel** onto the factory panel, then secure using (10) of the factory screws removed in step 1. (Figure B)

Continue to Kit Assembly

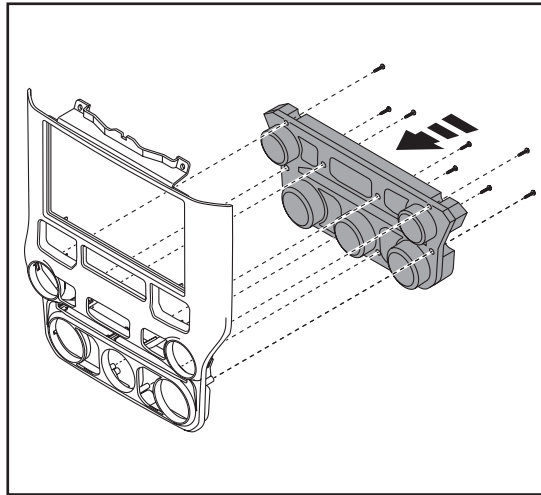

(Figure A)

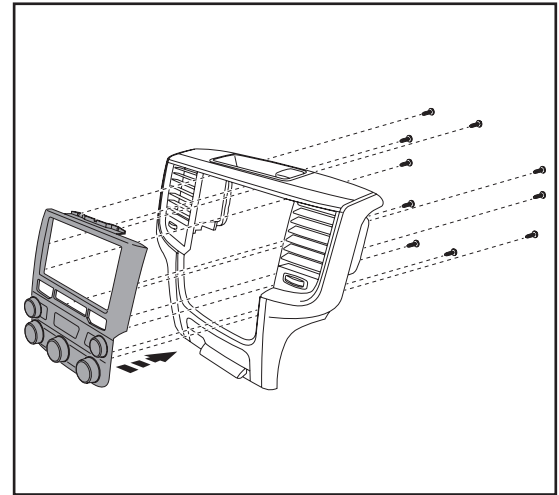

(Figure B)

KIT ASSEMBLY

Note: For single zone climate vehicles, remove the sync and max ac buttons from the display and button assembly and replace them with the included blank buttons.

Shallow chassis Double DIN radio provision

1. Secure the radio to the **radio brackets** using screws provided with the radio. (Figure A)
2. Secure the **Display and button assembly** using the (4) #6 x 3/8" Phillips screws provided. (Figure B)
3. Secure the radio/bracket assembly to the **radio trim panel/dash panel** assembly with the (4) #8 x 3/8 screws provided. (Figure C)

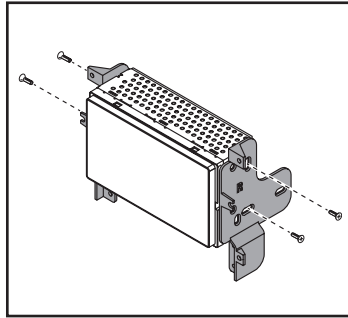

(Figure A)

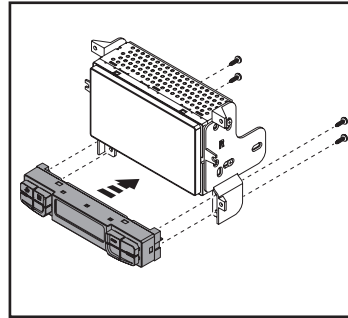

(Figure B)

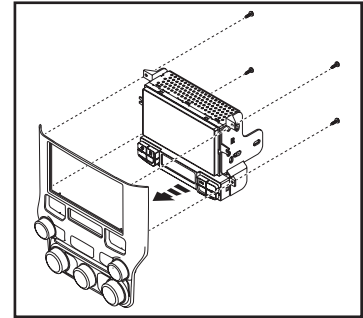

(Figure C)

Continued on the next page

KIT ASSEMBLY (CONT.)

Note: For single zone climate vehicles, remove the sync and max ac buttons from the display and button assembly and replace them with the included blank buttons.

L-shaped with chassis on bottom of radio:

1. Secure the radio/radio assembly to the **radio brackets** using screws provided with the radio. (Figure A)
2. Secure the **Display and button assembly** using the (4) #6 x 3/8" Phillips screws provided. (Figure B)
3. Secure the radio/bracket assembly to the **radio trim panel/dash panel** assembly with the (4) #8 x 3/8 screws provided. (Figure C)

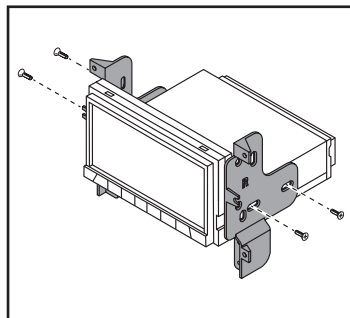

(Figure A)

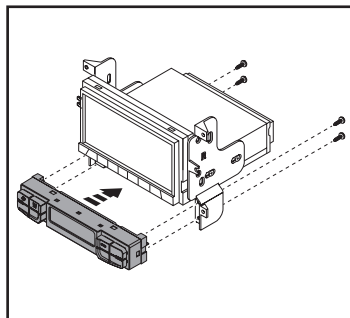

(Figure B)

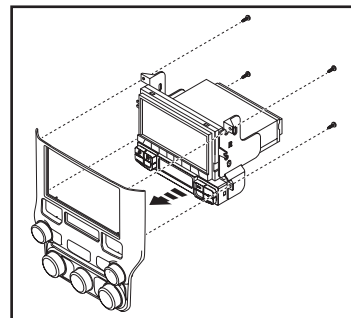

(Figure C)

Continued on the next page

KIT PREPARATION (CONT.)

Note: For single zone climate vehicles, remove the sync and max ac buttons from the display and button assembly and replace them with the included blank buttons.

Pioneer modular DDIN radio provision

Note: For steps 1 and 2, reference the installation manual provided with the radio for which hardware to use. The display screen and radio chassis use two different types of screws.

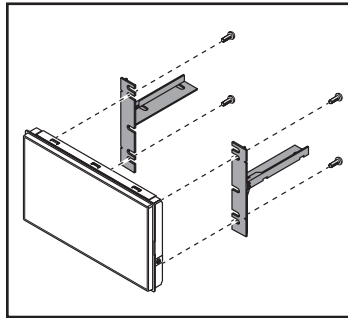

(Figure A)

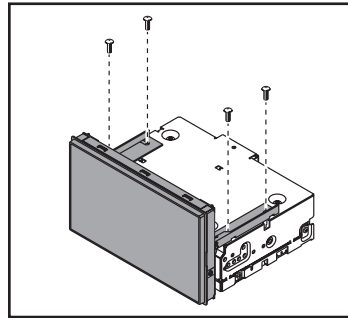

(Figure B)

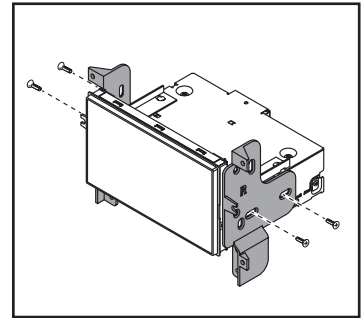

(Figure C)

1. Secure the radio display to the **Pioneer adapter brackets** using (4) screws supplied with the radio. (Figure A)
2. Connect the radio display/bracket assembly to the radio chassis using (4) screws supplied with the radio. (Figure B)
3. Secure the the **radio chassis brackets** to the radio display/bracket assembly using the screws supplied with the radio (Figure C)

Continued on the next page

KIT ASSEMBLY (CONT.)

Pioneer modular DDIN radio provision (cont.)

4. Secure the **Display and button assembly** using the (4) #6 x 3/8" Phillips screws provided. (Figure D)
5. Secure the radio/bracket assembly to the **radio trim panel/dash panel** assembly with the (4) #8 x 3/8 screws provided. (Figure E)

Continue to Access Interface Installation

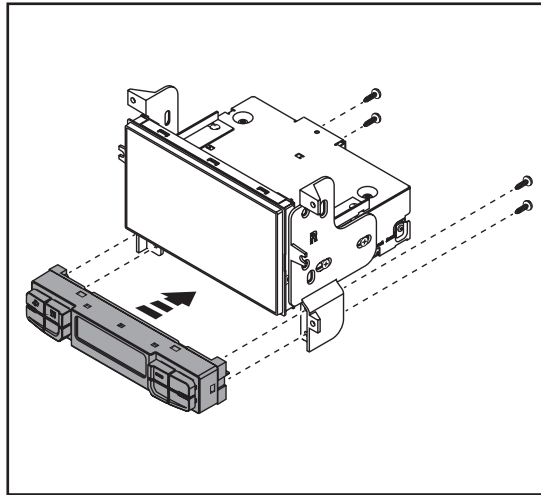

(Figure D)

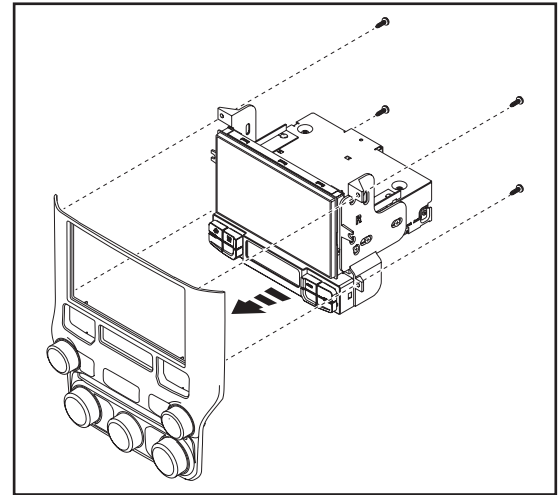

(Figure E)

AXXESS INTERFACE INSTALLATION

INTERFACE FEATURES

- Provides accessory power (12-volt 10-amp)
- Retains R.A.P. (retained accessory power)
- Provides illumination, parking brake, reverse, and speed sense outputs
- Retains audio controls on the steering wheel
- Allows retention and adjustment of the personalization options
- Retains safety chimes
- Retains the factory backup camera on 2500/3500 models
- Retains the factory AUX-IN jack (base models only)
- Can be used in amplified or non-amplified models
- Retains balance and fade*
- Micro-B USB updatable

** Non-amplified models only*

INTERFACE COMPONENTS

- Axxess interfaces
- Car side harnesses (LD-BX-CH5 or LD-DIS-CH8)
- 16-pin harness (LD-2NAVAMP)
- Hazard harness (LD-CHRYTAC)
- 3.5mm adapter

TABLE OF CONTENTS

Connections.....	10-11
Installation	12
Programming.....	13
Steering wheel control settings.....	14-17
Factory control panel button functions.....	18
Troubleshooting.....	19

TOOLS REQUIRED

- Crimping tool and connectors, or solder gun, solder, and heat shrink
- Tape • Wire cutter • Zip ties

Attention! This interface will work with models that are either non-amplified, or amplified. Please follow the instructions carefully for your model vehicle. Failure to do so will result in either no sound, or low sound. If you are unsure if your vehicle is factory amplified or not, please contact your local dealership.

CONNECTIONS

For models *without* a factory amplifier:

From the 16-pin harness to the aftermarket radio, connect the:

- **Red** wire to the accessory wire.
- **Blue/White** wire to the amp turn on wire.
- **Orange/White** wire to the illumination wire (if applicable).

Attention! The following (4) wires are reversed on purpose. These wires will not match “color code” to the aftermarket radio.

- **Gray** wire to the rear right positive speaker output.
- **Gray/Black** wire to the rear right negative speaker output.
- **White** wire to the rear left positive speaker output.
- **White/Black** wire to the rear left negative speaker output.

The following (3) wire are for multimedia/navigation radios that require them.

- **Blue/Pink** wire to the speed sense wire.
- **Green/Purple** wire to the reverse wire.
- **Light Green** wire to the parking brake wire.
- Tape off and disregard the following (5) wires, they will not be used in this application: **Brown, Green, Green/Black, Purple, Purple/Black**
- Disregard the 4-pin harness, it will not be used in this application.

From the car side harness to the aftermarket radio, connect the:

- **Black** wire to the ground wire.
- **Yellow** wire to the battery wire.
- **Gray** wire to the front right positive speaker output.
- **Gray/Black** wire to the front right negative speaker output.
- **White** wire to the front left positive speaker output.
- **White/Black** wire to the front left negative speaker output.
- **Yellow** RCA jack to the backup camera input (if applicable).
- **Red & White** RCA jacks to the audio AUX-IN jacks (only if the factory AUX-IN jack is desired to be used).
- Connect the (2) 4-pin connectors together.
- Tape off and disregard the following (2) wires, they will not be used in this application: **Blue/White** labeled “500L amp turn on”, **Red**
- Disregard the DIN jack, it will not be used in this application.

Continued on the next page

CONNECTIONS (CONT.)

For models with a factory amplifier:

From the 16-pin harness to the aftermarket radio, connect the:

- **Red** wire to the accessory wire.
- **Blue/White** wire to the amp turn on wire.
- **Orange/White** wire to the illumination wire (if applicable).

The following (3) wire are for multimedia/navigation radios that require them.

- **Blue/Pink** wire to the speed sense wire.
- **Green/Purple** wire to the reverse wire.
- **Light Green** wire to the parking brake wire.
- Tape off and disregard the following (9) wires, they will not be used in this application:
Gray, Gray/Black, White, White/Black, Green, Green/Black, Purple, Purple/Black, Brown

From the car side harness to the aftermarket radio, connect the:

- **Black** wire to the ground wire.
- **Yellow** wire to the battery wire.
- **Gray** wire to the front right positive speaker output.
- **Gray/Black** wire to the front right negative speaker output.
- **White** wire to the front left positive speaker output.
- **White/Black** wire to the front left negative speaker output.
- Connect the 4-pin harness to the main 52-pin connector:
- **Green** wire to the rear left positive speaker output.
- **Green/Black** wire to the rear left negative speaker output.
- **Purple** wire to the rear right positive speaker output.
- **Purple/Black** wire to the rear right negative speaker output.
- **Yellow** RCA jack to the backup camera input.
- **Red & White** RCA jacks to the audio AUX-IN jacks (only if the factory AUX-IN jack is desired to be used).
- Tape off and disregard the following (2) wires, they will not be used in this application:
Blue/White labeled "500L amp turn on", **Red**
- Disregard the DIN jack, it will not be used in this application.

INSTALLATION

With the vehicle completely off:

1. Connect 16-pin connector to interface
2. Connect 22-pin connector to interface
3. From the **LD-BX-CH5** or **LD-DIS-CH8 & LD-CHRYTAC** harnesses, connect the 2-pin plugs labeled with a "1" to each other. Also connect the 2-pin plug labeled "HVAC" to the 2-pin plug labeled "A"
4. Connect the 12-pin of the **LD-CHRYTAC** to the HVAC LCD SCREEN
5. Locate the factory antenna connector in the dash and complete all necessary connections to the radio. Use the antenna adapter provided to adapt the factory antenna to the aftermarket radio.

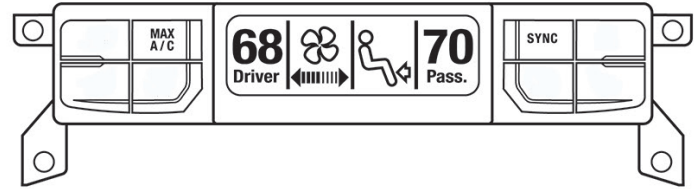
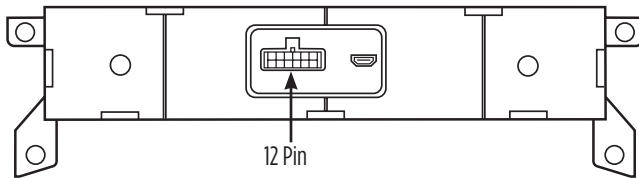

Description of button Assignments

MAX A / C

Max A/C

SYNC

Synchronization of temperatures to match driver's

3. From the **LD-BX-CH5** or **LD-DIS-CH8 & LD-CHRYTAC** harnesses, connect the 2-pin plugs labeled with a "1" to each other. Also connect the 2-pin plug labeled "HVAC" to the 2-pin plug labeled "A"

PROGRAMMING

For the steps below, the L.E.D. located inside the interface can only be seen while active. The interface does not need to be opened to see the L.E.D.

- Start the vehicle.
- Connect the **car side harness** to the wiring harness in the vehicle.
- The L.E.D. will initially turn on solid Green, then turn off for a few seconds while it auto detects the radio installed.
- The L.E.D. will then flash **Red** up to (18) times indicating which radio is connected to the interface, and then turn off for a couple of seconds. Pay close attention to how many **Red** flashes there are. This will help in troubleshooting, if need be. Refer to the **L.E.D. feedback** section for more information.
- After a couple seconds the L.E.D. will turn on solid **Red** while the interface auto detects the vehicle. The radio will shut off at this point. This process should take 5 to 30 seconds.
- Once the vehicle has been auto detected by the interface, the L.E.D. will turn on solid **Green**, and the radio will come back on, indicating programming was successful.
- Test all functions of the installation for proper operation, before reassembling the dash.

If the interface fails to function, refer to **Resetting the interface**.

Note: The L.E.D. will turn on solid **Green** for a moment, and then turn off under normal operation after the key has been cycled.

STEERING WHEEL CONTROL SETTINGS

L.E.D. Feedback: The (23) **Red L.E.D.** flashes represent a different radio manufacturer for the **SWC interface** to detect. For example, if you are installing a **JVC** radio, the **SWC interface** will flash **Red** (5) times, then stop. Following is the **L.E.D Feedback Legend**, which indicates the flash count of the radio manufacturer.

L.E.D. Feedback Legend

Flash Count	Radio
1	Eclipse (type 1) †
2	Kenwood ‡
3	Clarion (type 1) †
4	Sony / Dual
5	JVC
6	Pioneer / Jensen
7	Alpine *
8	Visteon
9	Valor
10	Clarion (type 2) †
11	Metra OE
12	Eclipse (type 2) †

Flash Count	Radio
13	LG
14	Parrot **
15	XITE
16	Philips
17	TBA
18	JBL
19	Insane
20	Magnadyne
21	Boss
22	Axxera
23	Axxerra (type 2)

KEYNOTES

* If the **SWC interface** flashes **Red** (7) times, and an **Alpine** radio is not installed, that means there is an open connection not accounted for. Verify that the 3.5mm jack is connected to the correct steering wheel jack/wire in the radio.

** The **AXSWCH-PAR** is required (sold separately). Also, the software in the radio must be rev. 2.1.4 or higher.

† If a **Clarion** or **Eclipse** radio is installed and the steering wheel controls do not function, change the radio to **Clarion (type 2)** or **Eclipse (type 2)** respectively. If the steering wheel controls still do not function, refer to the **Changing Radio Type** document available at axxessinterfaces.com.

‡ If a **Kenwood** radio is installed and the L.E.D. feedback flashes (5) times instead of (2), manually change the radio type to **Kenwood**. To do this, refer to the **Changing Radio Type** document available at axxessinterfaces.com.

Continued on the next page

STEERING WHEEL CONTROL SETTINGS (CONT.)

Attention: The **Axxess Updater App** can also be used to program the following (3) sub-sections as well, pending that the interface has been initialized and programmed.

Changing radio type

If the LED flashes do not match the radio you have connected, you must manually program the **Axxess interface** to tell it what radio it is connected to.

1. After (3) seconds of turning the key on, press and hold the Volume-Down button on the steering wheel until the L.E.D. in the AX-CH5-SWC goes solid.
2. Release the Volume-Down button; the L.E.D. will go out indicating we are now in Changing Radio Type mode.
3. Refer to the **Radio Legend** to know which radio number you would like to have programmed.
4. Press and hold the Volume-Up button until the L.E.D. goes solid, and then release. Repeat this step for the desired radio number you have selected.
5. Once the desired radio number has been selected, press and hold the Volume-Down button on the steering wheel until the L.E.D. goes solid. The L.E.D. will remain on for about (3) seconds while it stores the new radio information.
6. Once the L.E.D. goes off, the Changing Radio Type mode will then end. You can now test the steering control wheel controls.

Note: If at any time the user fails to press any button for a period longer than (10) seconds, this process will abort.

Radio Legend

- | | | | |
|---------------------|----------------------|----------------------|-------------|
| 1. Eclipse (Type 1) | 6. Pioneer/Jensen | 11. Metra OE | 16. Philips |
| 2. Kenwood | 7. Alpine | 12. Eclipse (Type 2) | 17. TBD |
| 3. Clarion (Type 1) | 8. Visteon | 13. LG | 18. JBL |
| 4. Sony/Dual | 9. Valor | 14. Parrot | |
| 5. JVC | 10. Clarion (Type 2) | 15. XITE | |

Continued on the next page

Remapping the steering wheel control buttons

Let's say you have **Axxess interface** initialized and you want to change the button assignment for the steering wheel controls. For example, you would like "Seek-Up" to be "Mute". Follow the steps below to remap the steering wheel control buttons:

1. Ensure the Axxess interface is visible so you can see the L.E.D. flashes to confirm button recognition.

Tip: Turning the radio off is recommended.

2. Within the first 20 seconds of turning the ignition on, press and hold the "Volume-Up" button on the steering wheel until the L.E.D. goes solid.
3. Release "Volume-Up", the L.E.D. will then go out; "Volume-Up" has now been programmed.
4. Follow the list in the **Button Assignment Legend**, to reference the order in which the steering wheel control buttons need to be programmed.

Note: If the next function on the list is not on the steering wheel, press the Volume-Up button for (1) second until the L.E.D. comes on, and then release the Volume-Up button. This will tell the Axxess interface that this function is not available and it will move on to the next function.

5. To complete the remapping process, press and hold the Volume-Up button on the steering wheel until the L.E.D. in the Axxess interface goes out.

Button Assignment Legend

1. Volume-Up	5. Source/Mode	10. Band	14. Off-Hook
2. Volume-Down	6. Mute	11. Play/Enter	15. Fan-Up *
3. Seek-Up/Next	7. Preset-Up	12. PTT (Push to Talk)	16. Fan-Down *
4. Seek-Down/ Prev	8. Preset-Down	13. On-Hook	17. Temp-Up *
	9. Power		18. Temp-Down *

Note: Not all radios will have all of these commands. Please refer to the manual provided with the radio, or contact the radio manufacturer for specific commands recognized by that particular radio.

Continued on the next page

STEERING WHEEL CONTROL SETTINGS (CONT.)

Dual assignment instructions (long button press)

The **Axxess interface** has the capability to assign (2) functions to a single button, except Volume-Up and Volume-Down. Follow the steps below to program the button(s) to your liking.

Note: Seek-Up and Seek-Down come pre-programmed as Preset-Up and Preset-Down for a long button press.

1. Turn on the ignition but do not start the vehicle.
2. Press and hold down the steering wheel control button that you want to assign a long press function to for about (10) seconds, or until the L.E.D. flashes rapidly. At this point release the button; the L.E.D. will then go solid.
3. Press and release the Volume-Up button the number of times corresponding to the new button number selected. Refer to the **Dual Assignment Legend**. The L.E.D. will flash rapidly while the Volume-Up button is being pressed, and then go back to a solid L.E.D. once released. Go to the next step once the Volume-Up button has been pressed the desired number of times.
Caution: If more than (10) seconds elapses between pressing the Volume-Up button, this procedure will abort, and the L.E.D. will go out.
4. To store the long press button in memory, press the button that you assigned a long press button to (the button held down in Step 2). The L.E.D. will now go off indicating the new information has been stored.

Note: These steps must be repeated for each button you would like to assign a dual purpose feature to. To reset a button back to its default state, repeat Step 1, and then press the Volume-Down button. The L.E.D. will go out, and the long press mapping for that button will be erased.

Dual Assignment Legend

- | | | | |
|-------------------|----------------|----------------|-----------------|
| 1. Not allowed | 6. ATT/Mute | 11. Play/Enter | 16. Fan-Down * |
| 2. Not allowed | 7. Preset-Up | 12. PTT | 17. Temp-Up * |
| 3. Seek-Up/Next | 8. Preset-Down | 13. On-Hook | 18. Temp-Down * |
| 4. Seek-Down/Prev | 9. Power | 14. Off-Hook | |
| 5. Mode/Source | 10. Band | 15. Fan-Up * | |

* Not applicable in this application

FACTORY CONTROL PANEL BUTTON FUNCTIONS

Factory Control panel will vary from vehicles (refer to images provided)

Note: Some factory controls are retained (ex. Audio and HVAC can be controlled from factory panel) the following buttons will not work or will perform a different action.

Buttons not working or have a different assignment

- Screen OFF : NA
- BACK : EXITS PREVIOUS SCREEN FROM VEHICLE OPTIONS SECTION
- Right Rotary Knob: will change to previous track or cycle through stations. (When button is pressed as “Enter” you will be able to cycle through the Vehicle options that were equipped with, by turning the knob and then pressing the enter once option is reached. Turn knob to make change on option(refer to owner’s manual for setting and selectable options)



8.4 NAV with Automatic Temperature Control

TROUBLESHOOTING

Resetting the interface

1. The Blue reset button is located inside the interface, between the two connectors. The button is accessible outside the interface, no need to open the interface.
2. Press and hold the reset button for two seconds, and then let go to reset the interface.
3. Refer to **“Programming the Interface”** from this point.

Redecting vehicle's vehicle options (Vehicle Options may vary, refer to vehicle's owner's manual for vehicle options that came equipped with vehicle) on the HVAC LCD.

1. With vehicle running (On Position/Ignition On)
2. Hold Sync and Max AC button for 8seconds (LCD will display DECTION IN PROGRESS XX/YY

FINAL ASSEMBLY

1. Snap the radio/dash panel assembly into the dash. Reassemble the dash in reverse order of disassembly.



107-CH6B

INSTALLATION INSTRUCTIONS



Having difficulties? We're here to help.



Contact our Tech Support line at:

386-257-1187



Or via email at:

techsupport@metra-autosound.com

Tech Support Hours (Eastern Standard Time)

Monday - Friday: 9:00 AM - 7:00 PM

Saturday: 10:00 AM - 5:00 PM

Sunday: 10:00 AM - 4:00 PM



**Metra recommends MECP
certified technicians**