



Ford Multi Kit (Vehicles with factory 8" screen) **2011-2024**

Visit MetraOnline.com for more detailed information about the product and up-to-date vehicle specific applications

KIT FEATURES

- Designed for most shallow chassis DDIN or Pioneer Modular Chassis 6.8" radios
- A radio replacement interface will be necessary to retain certain climate control features and access to vehicle customization menus previously accessed on the factory screen.
- Three sets of brackets to cover many applications and four more Pioneer modular radio brackets are also included for remote chassis mounting options.
- Brass inserts are molded into the brackets for durability and to utilize the factory screen brackets and hardware.

KIT COMPONENTS

- A) Radio trim panel • B) Radio bracket 1 • C) Radio bracket 2 • D) Radio bracket 3 • E) Radio bracket 4 • F) Radio bracket A • G) Radio bracket B • H) Radio bracket C • I) #8 x 3/8" Phillips screws (4)

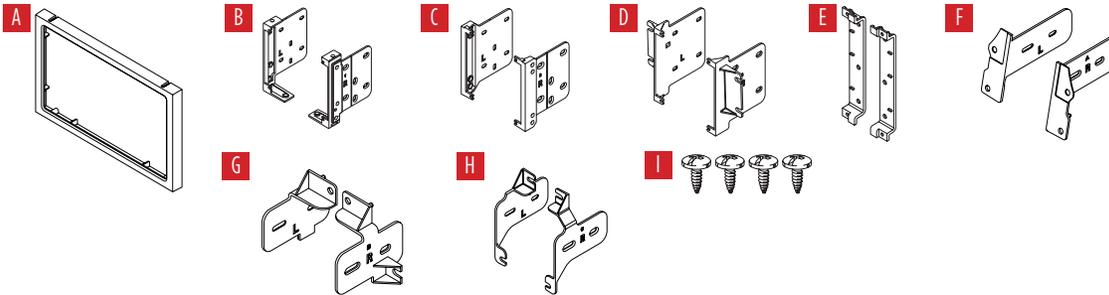

APPLICATIONS

See inside front cover

TABLE OF CONTENTS

See inside front cover

TOOLS REQUIRED

- Panel removal tool • Phillips screwdriver
- Socket wrench • T-25 Torx driver

WIRING & ANTENNA CONNECTIONS SOLD SEPERATELY

Attention! With the key out of the ignition, disconnect the negative battery terminal before installing this product. Ensure that all installation connections are secure before cycling the ignition to test this product.

APPLICATIONS

Ford

Edge	2011-2020
Escape.....	2013-2019
Note: Escape is bottom L-shape chassis only or Pioneer modular with chassis on bottom. Shallow mount requires sub dash mods.	
Expedition	2015-2021
Explorer	2011-2019
F-150.....	2013-2014
Flex.....	2013-2019
Focus.....	2012-2018
Fusion	2013-2019
Mustang.....	2015-2022
Ranger	2019-2021
Super Duty.....	2013-2022
Taurus	2013-2019

TABLE OF CONTENTS

Dash Disassembly

- Edge 2011-2014	3
- Edge 2015-2020.....	4-5
- Edge 2015-2020 (Rotary shifter)	6-7
- Escape 2013-2019.....	8-9
- Expedition 2015-2017	10-11
- Expedition 2018-2021.....	12-13
- Explorer 2011-2019	14
- F-150 2013-2014	15
- F-150 2015-2020	16-17
- Flex 2013-2019	18-19
- Focus 2012-2018.....	20
- Fusion 2013-2019	21
- Mustang 2015-2022	22-23
- Ranger 2019-2023	24-25
- Super Duty 2013-2022.....	26-27
- Taurus 2013-2019.....	28-29

Note: Some disassembly drawings re-use drawings from small screen equipped cars. The disassembly process is the same or similar.

Kit Assembly

Bracket 1	30-34
- Edge 2011-2020	
- Explorer 2011-2019	
- Super Duty 2013-2022	
- F-150 2013-2014	
- Flex 2013-2019	
- Taurus 2013-2019	
Bracket 2	35-38
- Expedition 2015-2021	
- F-150 2015-2020	
- Fusion 2013-2019	
- Mustang 2015-2022	
- Ranger 2019-2021	
- Focus 2012-2018	
- Escape 2013-2019	
- Ranger 2019-2021	
Bracket 3	39-41
- Ranger 2022-2023	

DASH DISASSEMBLY

Ford Edge 2011-2014

Note: Small screen disassembly shown.

1. Unclip and remove the (2) trim panels from the left and right side of the factory radio. (Figure A)
2. Remove (4) T-20 Torx screws securing the trim panel around the gear shifter, then, using the panel removal tool, unclip and remove the panel. (Figure B)
3. Remove (6) 9/32" screws securing the radio/climate control panel to the dash. (Figure C)

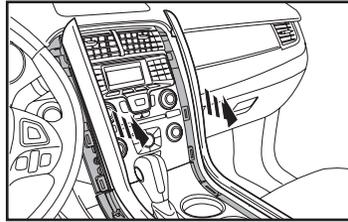

(Figure A)

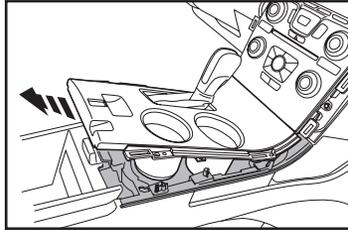

(Figure B)

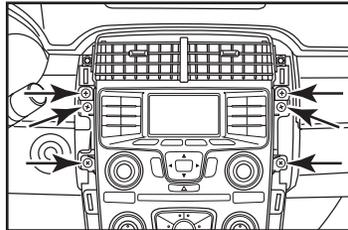

(Figure C)

4. Using the panel removal tool, carefully unclip, unplug, and remove the factory radio/climate control panel. (Figure D)
5. Remove (4) 9/32" screws securing the radio chassis, disconnect the wiring, and then remove the radio. (Figure E)
6. Remove (4) 9/32" screws securing the factory display, then unplug and remove. (Figure E)

Continue to Kit Assembly

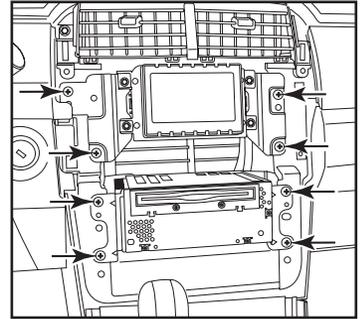

(Figure D)

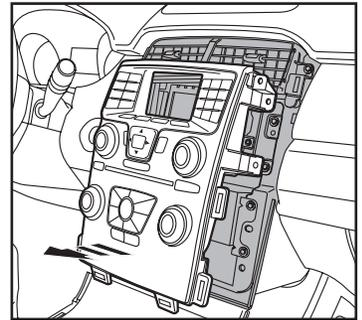

(Figure E)

DASH DISASSEMBLY

Ford Edge 2015-2020 (with shift lever)

1. Unclip and remove the center console trim panel. (Figure A)
2. Unclip and remove the trim panels from the sides of the center console. (Figure B)

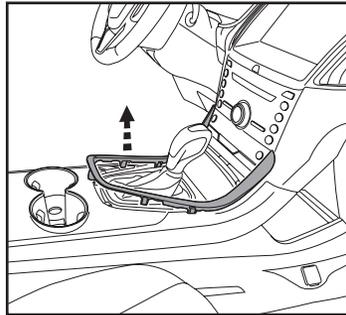

(Figure A)

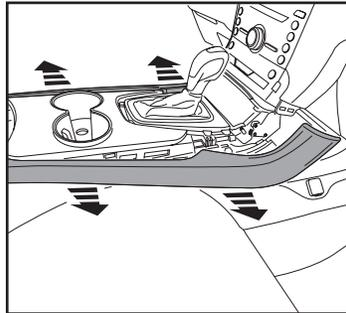

(Figure B)

3. Unclip, unplug, and remove the center console trim panel. Be careful not to scratch the radio with the front clips. (Figure C)
4. Remove (4) 7/32" screws securing the storage compartment in the front of the center console, then move it aside. (Figure D)

Continued on the next page

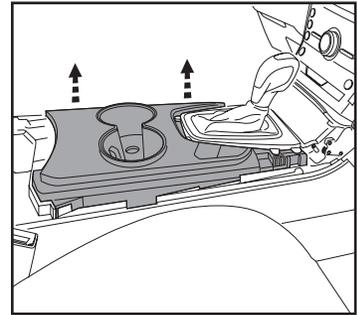

(Figure C)

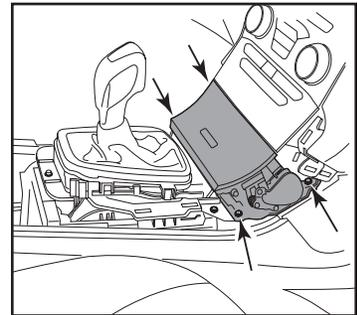

(Figure D)

DASH DISASSEMBLY (CONT.)

Ford Edge 2015-2020 (with shift lever, cont.)

4. Remove (5) 9/32" screws securing the shifter housing, then unclip it by pulling back and up to release the clips in the front of the housing. The housing does not need to be removed, just pulled back during disassembly. (Figure E)
5. Remove (2) 9/32" screws securing the bottom of the radio/climate control panel. (Figure F)
6. Starting from the bottom of the radio/climate control panel, unclip the panel, pulling towards the back of the vehicle to release the clips. Unplug and remove the panel. (Figure F)

Note: Use caution when removing this panel. The top of the panel above the vents can break off easily.

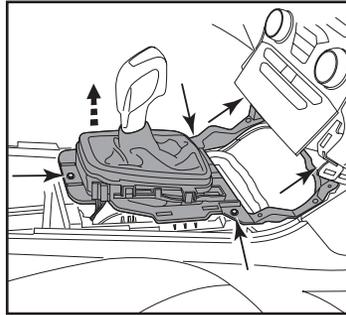

(Figure E)

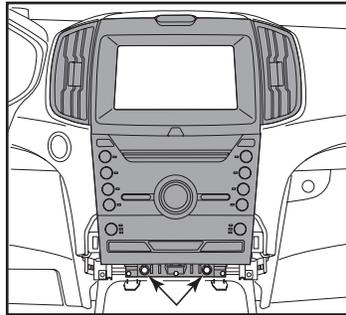

(Figure F)

7. Remove (4) screws securing the radio display, then unplug and remove. (Figure G)
8. Slide out the radio chassis, then unplug and remove. (Figure G)

Continue to Kit Assembly

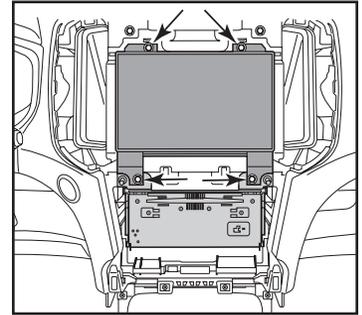

(Figure G)

DASH DISASSEMBLY

Ford Edge 2015-2020 (with rotary shifter)

1. Unclip and remove the (2) center console trim panels. (Figure A)
2. Unclip and remove the trim panels from the sides of the center console. (Figure B)

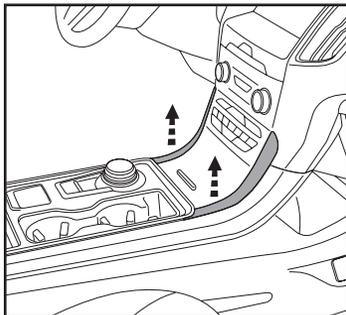

(Figure A)

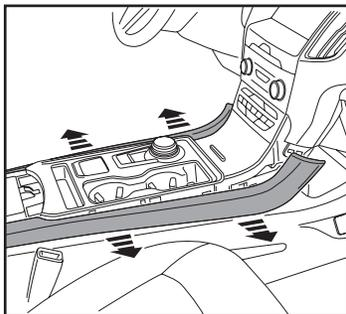

(Figure B)

3. Unclip, unplug, and remove the center console trim panel. Be careful not to scratch the radio with the front clips. (Figure C)
4. Remove (4) 7/32" screws securing the storage compartment in the front of the center console, then move it aside. (Figure D)

Continued on the next page

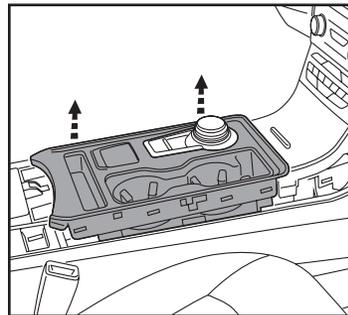

(Figure C)

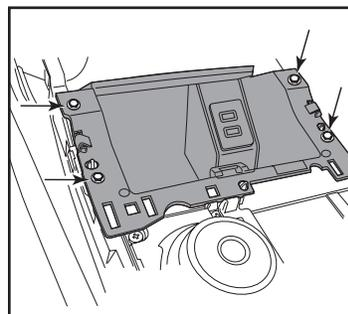

(Figure D)

DASH DISASSEMBLY (CONT.)

Ford Edge 2015-2020 (with rotary shifter, cont.)

- Remove (5) 9/32" screws securing the shifter housing, then unclip it by pulling back and up to release the clips in the front of the housing. The housing does not need to be removed, just pulled back during disassembly. (Figure E)
- Remove (2) 9/32" screws securing the bottom of the radio/climate control panel. (Figure F)

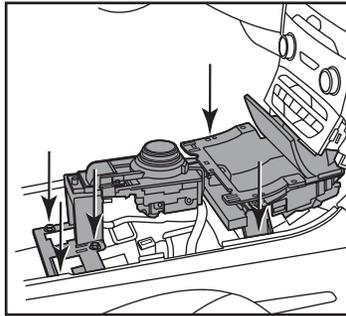

(Figure E)

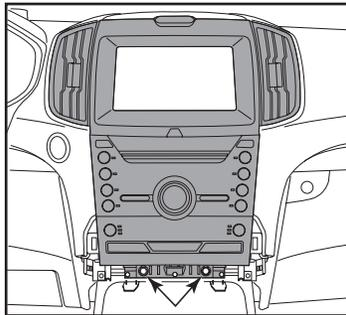

(Figure F)

- Starting from the bottom of the radio/climate control panel, unclip the panel, pulling towards the back of the vehicle to release the clips. Unplug and remove the panel. (Figure G)

Note: Use caution when removing this panel. The top of the panel above the vents can break off easily.

- Remove (4) screws securing the radio display, then unplug and remove. (Figure G)
- Slide out the radio chassis, then unplug and remove. (Figure G)

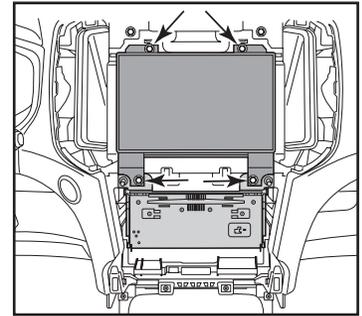

(Figure G)

Continue to Kit Assembly

DASH DISASSEMBLY

Ford Escape 2013-2019

1. Unclip and remove the top trim panel above the display screen. (Figure A)
2. Remove (2) T-25 Torx screws securing the screen to the dash, then unclip and remove the screen by pulling straight up. (Figure B)
3. Unclip and remove the trim panel above the radio. (Figure C)
4. Remove (3) 7mm screws exposed, (2) in the front, and (1) in the rear, then unclip and remove the trim panel above the radio. (Figure D)

Continued on the next page

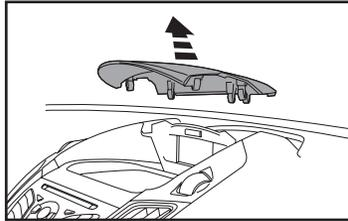

(Figure A)

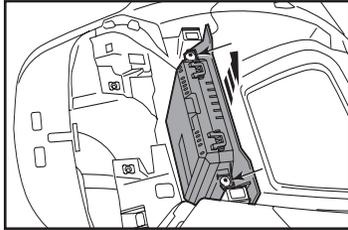

(Figure B)

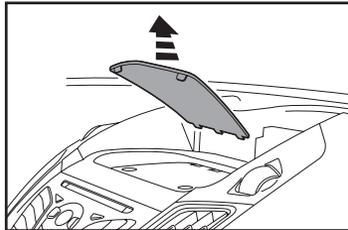

(Figure C)

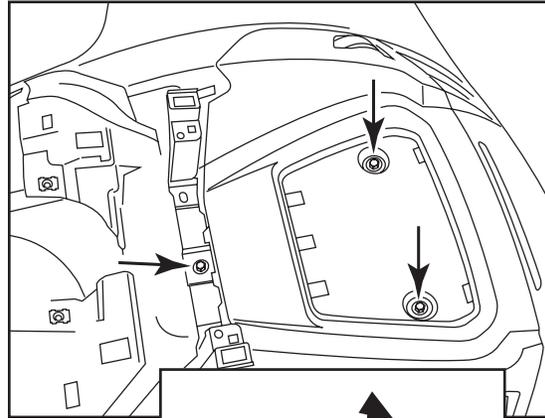

(Figure D)

DASH DISASSEMBLY (CONT.)

Ford Escape 2013-2019 (cont.)

5. Remove (2) 7mm screws from the radio face, then unclip, unplug and remove the face from the dash. (Figure E)
6. Remove (2) 7mm screws at the top of the CD drive and then remove the drive from the dash cavity. (Figure F)
7. Cut the shaded area from the sub-dash cavity. (Figure G)

Continue to Kit Assembly

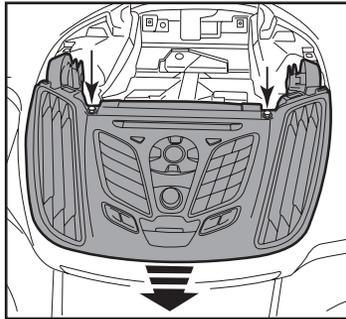

(Figure E)

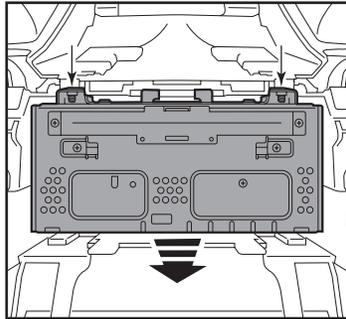

(Figure F)

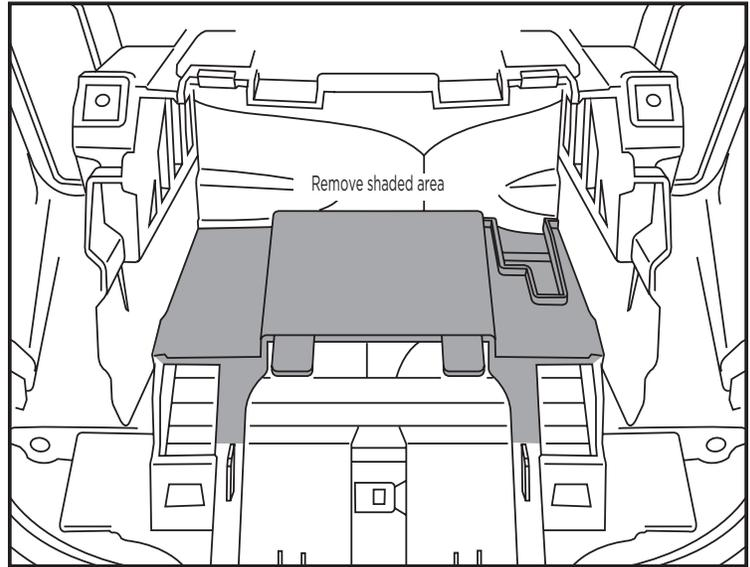

(Figure G)

DASH DISASSEMBLY

Ford Expedition 2015-2017

Note: Climate control module needs to be relocated to the bottom where the oem radio body was.

1. Unclip and remove the trim panel at the bottom of the climate control panel. (Figure A)
2. Remove (2) 7mm screws behind it. (Figure B)

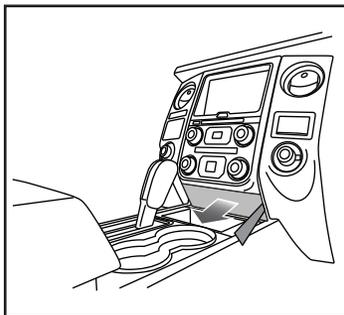

(Figure A)

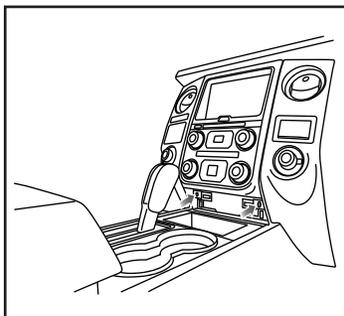

(Figure B)

3. Unclip and remove the radio and climate control panel, starting from the bottom. Unplug the connectors. (Figure C)
4. Remove (4) screws holding the radio. (Figure D)

Continued on the next page

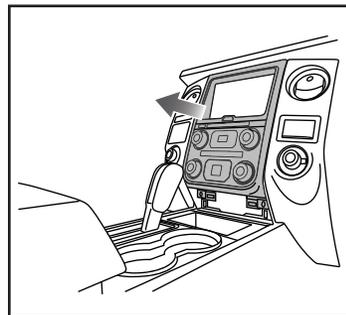

(Figure C)

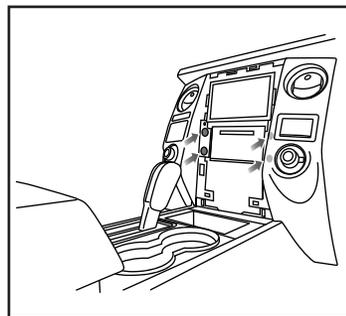

(Figure D)

DASH DISASSEMBLY (CONT.)

Ford Expedition 2015–2017 (cont.)

5. Remove and unplug the radio. (Figure D)
6. Remove and unplug the screen. (Figure E)
7. Unplug the climate module, above the OEM screen location. Remove (1) 7mm screw and remove the module. The climate module will be relocated to the bottom, where the oem radio body was. (Figure F)

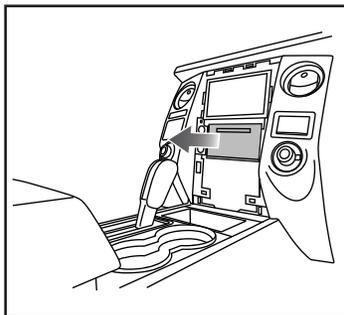

(Figure E)

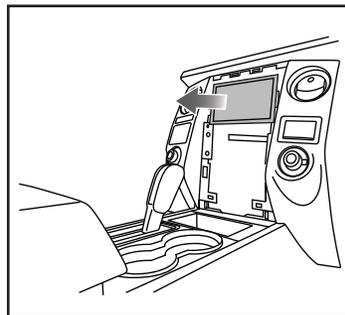

(Figure F)

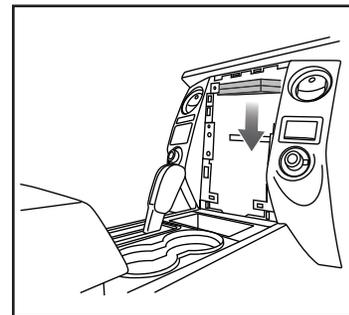

(Figure G)

Continue to Kit Assembly

DASH DISASSEMBLY

Ford Expedition 2018–2021

Note: Small screen disassembly shown.

- 1. For vehicles with a center channel speaker:** Unclip and remove the speaker grille in the center of the dash above the radio/climate control panel, and then remove the (2) 9/32" screws exposed. (Figure A)
- 2. For vehicles without a center channel speaker:** Remove the rubber pad in the shallow pocket above the radio/climate control panel, and then remove the (2) 9/32" screws exposed. (Figure B)
- 3.** Unclip and remove the panel above the radio/climate control panel, and then remove the (2) 9/32" screws from the top of the radio/climate control panel. (Figure C)

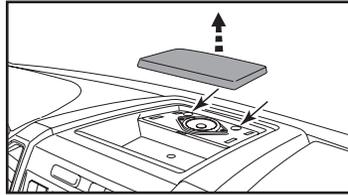

(Figure A)

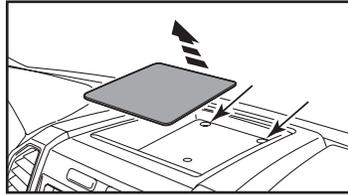

(Figure B)

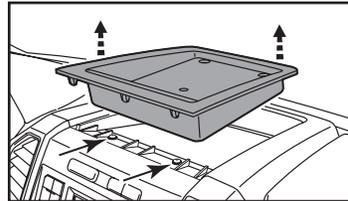

(Figure C)

Ensure that the vehicle is completely off before proceeding onto the following (5) steps

- 4.** Using the panel removal tool, carefully unclip, unplug, and remove the radio/climate control panel.
- 5.** Remove the 9/32" Phillips screws securing the display screen: (6) for 8-inch display screen models, then unplug and remove the screen. (Figure D)

Continued on the next page

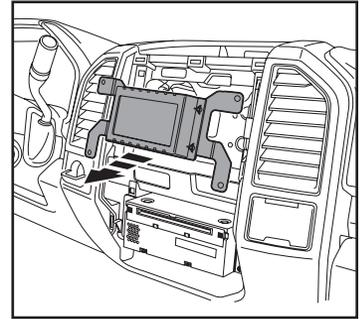

(Figure D)

DASH DISASSEMBLY (CONT.)

Ford Expedition 2018-2021 (cont.)

- Remove (4) 9/32" screws securing the radio chassis, disconnect the wiring, and then remove the factory radio. (Figure F)
- For models equipped with a factory backup camera:** Remove the (2) 10mm nuts located at the top of the camera module. Loosen the bottom nut and reposition the module down onto the lower stud, then re-secure using just (1) 10mm nut. (Figure G)

Continue to Kit Assembly

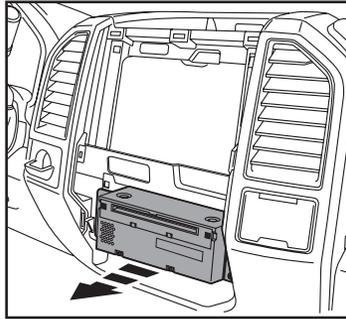

(Figure F)

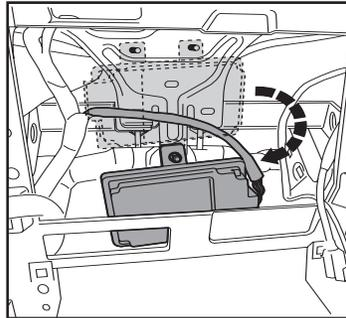

(Figure G)

DASH DISASSEMBLY

Ford Explorer 2011-2019

Note: Small screen disassembly shown.

1. Unclip and remove the (2) trim panels from the left and right side of the factory radio. (Figure A)
2. Remove (4) 9/32" screws securing the radio/climate control panel to the dash. (Figure B)
3. Unclip, unplug, and remove the factory radio/climate control panel. (Figure C)

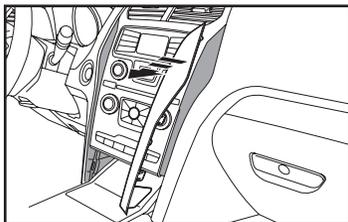

(Figure A)

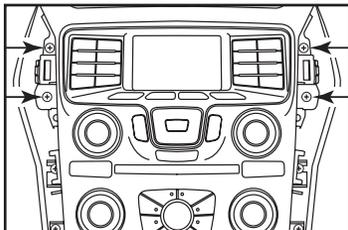

(Figure B)

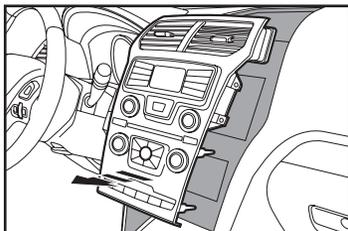

(Figure C)

4. Remove (4) 9/32" screws securing the radio chassis, then unplug and remove. (Figure D)
5. Remove (4) 9/32" screws securing the factory display, then unplug and remove. (Figure E)

Continue to Kit Assembly

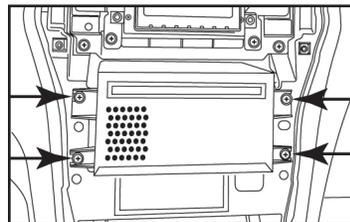

(Figure D)

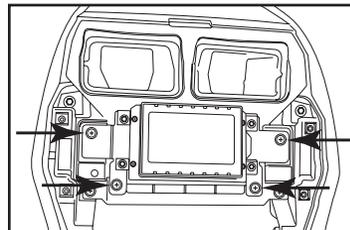

(Figure E)

DASH DISASSEMBLY

Ford F-150 2013-2014

Note: Small screen disassembly shown.

1. Open and lower the glove box, then remove (3) 8mm bolts from inside the glove box facing up. (Figure A)
2. Remove (1) 7mm screw securing the trim panel to the right of the radio, then unclip and set to the side. (Figure B)
3. Remove (4) 9/32" screws securing the radio/climate control panel to the dash, then unclip, unplug, and remove. (Figure C)

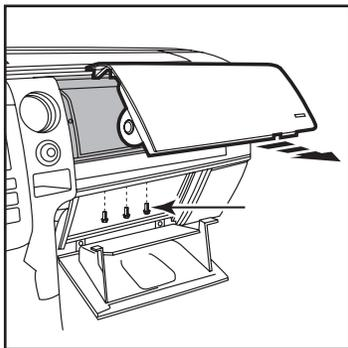

(Figure A)

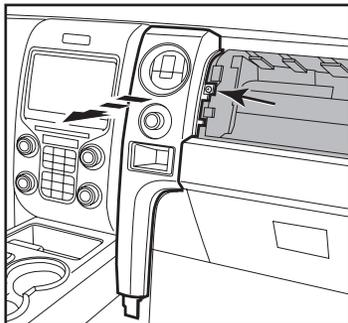

(Figure B)

4. Remove (4) 9/32" screws securing the radio chassis, then unplug and remove. (Figure D)
5. Remove (4) 9/32" screws securing the factory display, then unplug and remove. (Figure D)
6. Unsnap, unplug, and remove the traction control button and save for kit assembly.

Continue to Kit Assembly

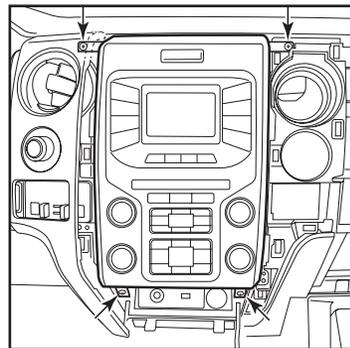

(Figure C)

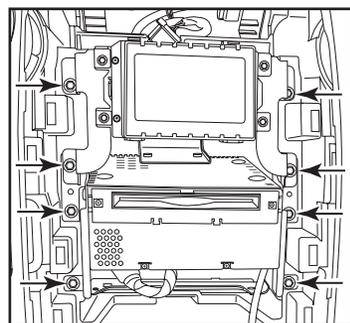

(Figure D)

DASH DISASSEMBLY

Ford F-150 2015-2020

- 1. For vehicles with a center channel speaker:** Unclip and remove the speaker grille in the center of the dash above the radio/climate control panel, and then remove the (2) 9/32" screws exposed. (Figure A)
- 2. For vehicles without a center channel speaker:** Remove the rubber pad in the shallow pocket above the radio/climate control panel, and then remove the (2) 9/32" screws exposed. (Figure B)
- 3.** Unclip and remove the panel above the radio/climate control panel, and then remove the (2) 9/32" screws from the top of the radio/climate control panel. (Figure C)

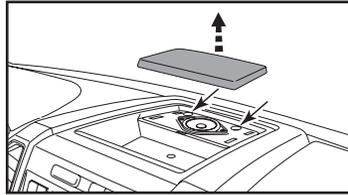

(Figure A)

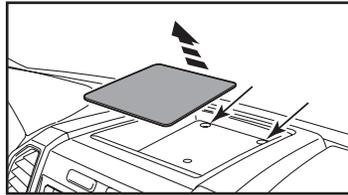

(Figure B)

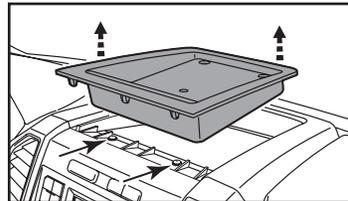

(Figure C)

Ensure that the vehicle is completely off before proceeding onto the following (5) steps

- 4.** Using the panel removal tool, carefully unclip, unplug, and remove the radio/climate control panel.
- 5.** Remove the 9/32" Phillips screws securing the display screen: (6) for 8-inch display screen models, then unplug and remove the screen. (Figure D)

Continued on the next page

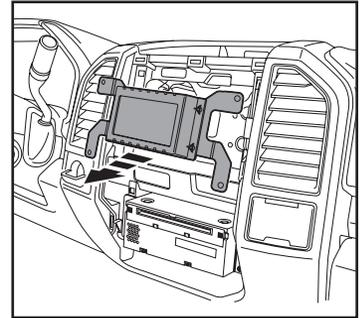

(Figure D)

DASH DISASSEMBLY (CONT.)

Ford F-150 2015-2020 (cont.)

- Remove (4) 9/32" screws securing the radio chassis, disconnect the wiring, and then remove the factory radio. (Figure F)
- For models equipped with a factory backup camera:** Remove the (2) 10mm nuts located at the top of the camera module. Loosen the bottom nut and reposition the module down onto the lower stud, then re-secure using just (1) 10mm nut. (Figure G)

Continue to Kit Assembly

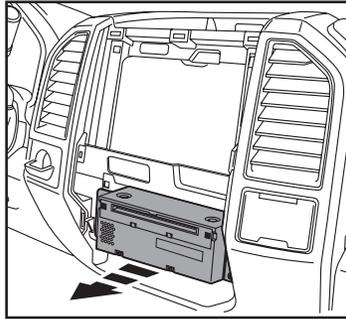

(Figure F)

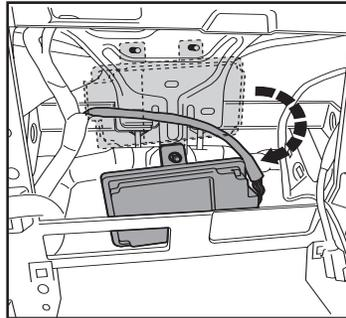

(Figure G)

DASH DISASSEMBLY

Ford Flex 2013-2019

Note: Small screen disassembly shown.

1. Unclip and remove the trim panel extending across the dash at the top of the factory radio panel to the passenger air vent. (Figure A)
2. Remove (2) 9/32" screws from the top of the factory radio trim panel. (Figure B)

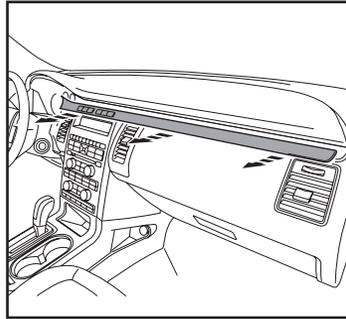

(Figure A)

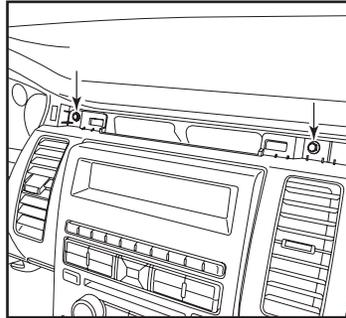

(Figure B)

3. Unclip and remove the chrome trim around the shifter on the top of the center console (Figure C).
4. Unclip and remove the top of the center console including the cup holders then remove (2) 9/32" screws from the bottom of the factory radio trim panel. (Figure D)

Continued on the next page

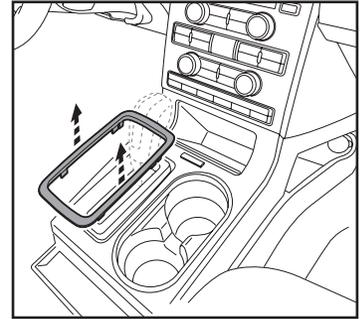

(Figure C)

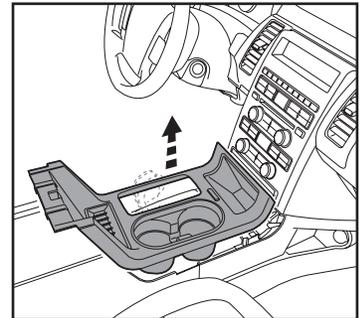

(Figure D)

DASH DISASSEMBLY (CONT.)

- Unclip each side of the center console to reveal (1) 9/32 screw (per side) securing the factory radio trim panel, and remove the screw. (Figures E, F)

Note: You do not need to remove the panels completely, you can unclip them half way back to gain access to the screw.

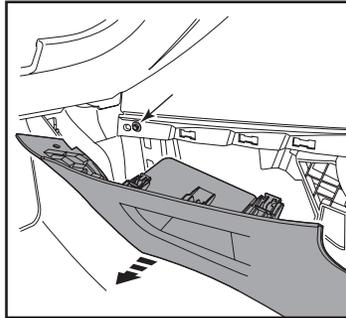

(Figure E)

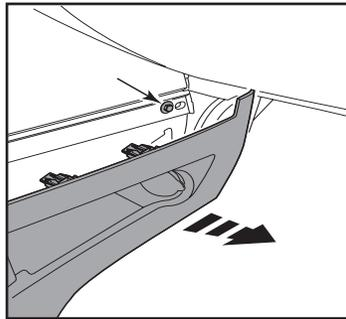

(Figure F)

- Unclip and remove the radio trim panel including the a/c vents and the factory radio/climate controls. (Figure G)
- Unclip and move to the side the thermistor (if equipped) attached to the radio trim panel.
- Remove (4) 9/32" screws securing the factory display. (Figure H)
- Remove (4) 9/32" screws securing the factory radio chassis. (Figure H)

Continue to Kit Assembly

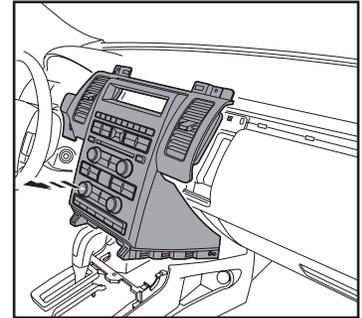

(Figure G)

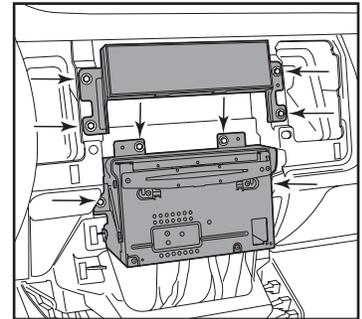

(Figure H)

DASH DISASSEMBLY

Ford Focus 2012-2018

1. Unclip, unplug, and remove the trim panel with the passenger airbag light in it. Keep the airbag light for Kit Preparation. (Figure A)
2. Unclip and remove the trim panel around the shifter panel. (Figure B)
3. Remove (3) Phillips screws securing the shifter panel, then unclip and slide the shifter panel toward the rear of the vehicle. (Figure C)

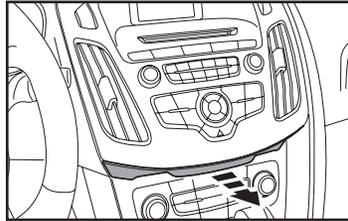

(Figure A)

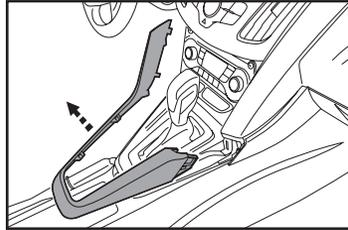

(Figure B)

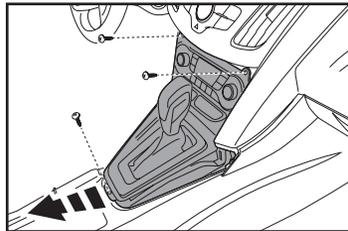

(Figure C)

4. Remove (2) T-25 Torx screws from the bottom of the radio panel. (Figure D)
5. Unclip, unplug and remove the radio control panel including the A/C vents. (Figure E)
6. Remove (2) T-25 Torx screws securing the radio, and (4) T-25 Torx screws securing the display and bracket, and then unplug and remove. (Figure F)

Continue to Kit Assembly

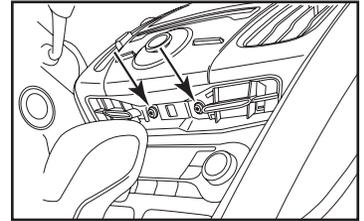

(Figure D)

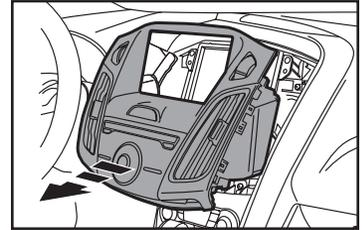

(Figure E)

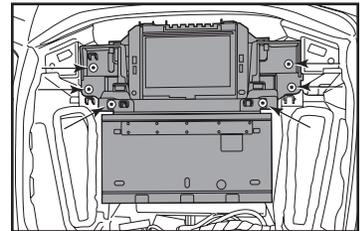

(Figure F)

DASH DISASSEMBLY

Ford Fusion 2013-2019

For 2013-2016 models only:

1. Unclip the trim from around the shifter. (Figure A)
2. Unclip the U-shaped trim from the rear of the shifter. (Figure B) 14-16 only

For 2017-2019 models only:

3. Remove the left and right side panels on the center console, and then remove the (2) 7mm screws exposed. (Figure C)

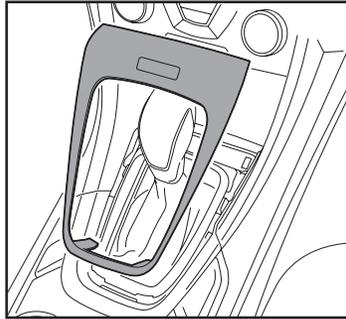

(Figure A)

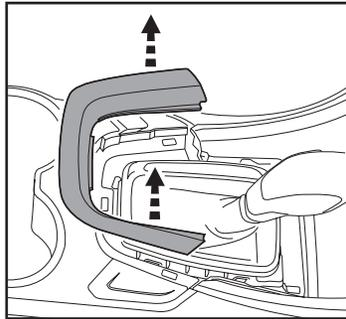

(Figure B)

All models:

Note: Small screen disassembly shown.

4. Unclip the trim surrounding the center dash. (Figure D)

Ensure that the vehicle is completely off before proceeding onto the following (3) steps

5. Remove the (2) 9/32" screws securing the radio/climate control panel, and then unclip, unplug, and remove.
6. Remove the (4) 9/32" screws securing the display screen, and then unplug and remove.
7. Remove the (2) 9/32" screws securing the radio chassis, and then unplug and remove.

Continue to Kit Assembly

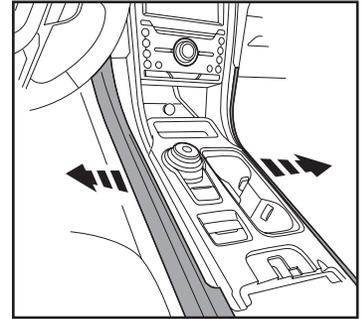

(Figure C)

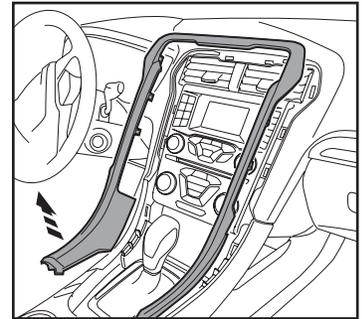

(Figure D)

DASH DISASSEMBLY

Ford Mustang 2015-2022

1. Open the passenger door and remove the trim panel from the side of the dash. (Figure A)
2. Open the glove box and remove the trim panel on the right side. (Figure B)
3. Unclip and remove the trim/vent dash panel. (Figure C)

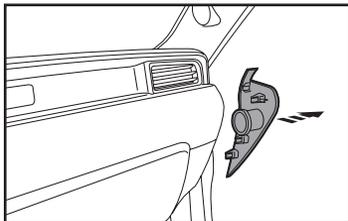

(Figure A)

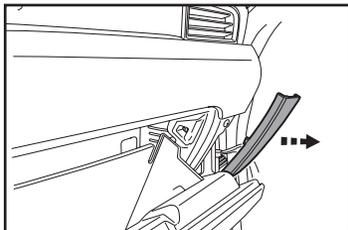

(Figure B)

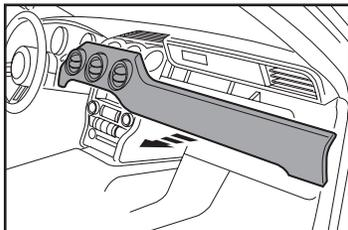

(Figure C)

4. Remove the rubber tray cover in front of the shifter, and then remove the (2) 9/32" screws exposed. (Figure D)
5. Unclip and remove the front side panels from each side of the center console. (Figure E)
6. Remove the (2) 9/32" screws from each side of the center console. (Figure F)

Continued on the next page

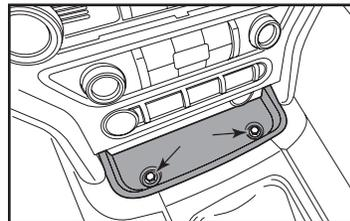

(Figure D)

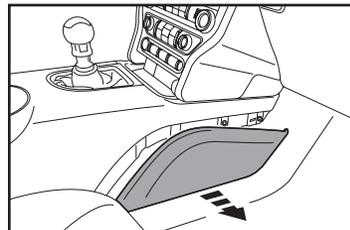

(Figure E)

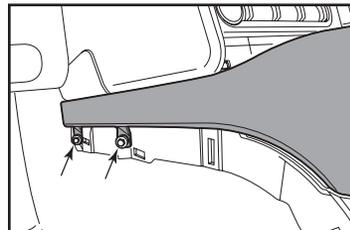

(Figure F)

DASH DISASSEMBLY (CONT.)

- Unclip the shifter trim bezel and slightly pull it up to clear the center console trim bezel removal.
- Open the center console storage compartment. Unclip the center console trim bezel, then slide it toward the rear of the vehicle to remove it. (Figure G)

Note: The complete center console does not need to be removed, but if it is desired to be removed, the Push-to-Start module must be connected when testing the kit.

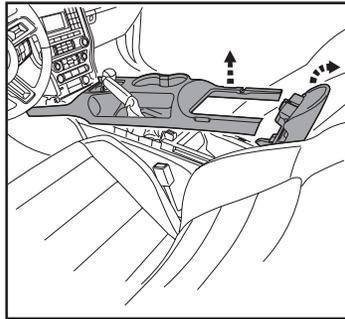

(Figure G)

- Remove the plastic tray in front of the shifter.
- Remove the center plastic trim (knockout) between the power outlet and USB jack. (Figure H)

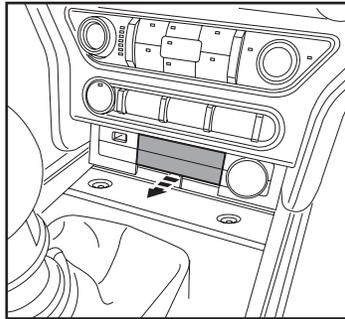

(Figure H)

Ensure that the vehicle is completely off before proceeding onto the following (3) steps:

- Remove the (4) 9/32" screws securing the radio/climate control panel, and then unclip, unplug, and remove. (Figure I)
- Remove the (4) 9/32" screws securing the display screen, then unplug and remove. (Figure J)
- Remove the (4) 9/32" screws securing the radio chassis, then unplug and remove. (Figure J)

Continue to Kit Assembly

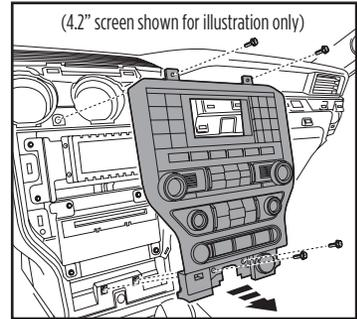

(Figure I)

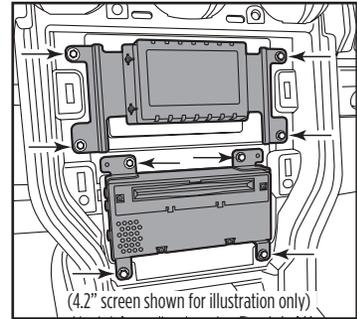

(Figure J)

DASH DISASSEMBLY

Ford Ramger 2019-2023

Note: Figures A-F show the 8" display model radio for illustration purposes only.

1. Unclip and remove the passenger side a/c vent & dash panel assembly. (Figure A)
2. Unclip and remove the a/c vent to the left of the radio. (Figure B)

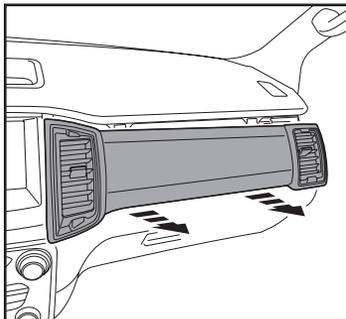

(Figure A)

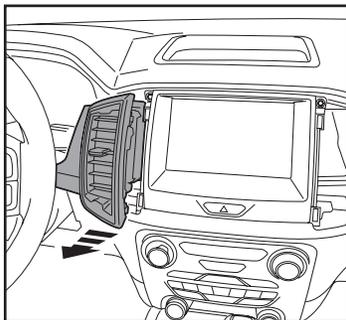

(Figure B)

3. Unclip and remove the lower trim panels to the left and right of the climate controls. (Figure C)
4. Unclip and remove the lower dash panel. (Figure D)

Continued on the next page

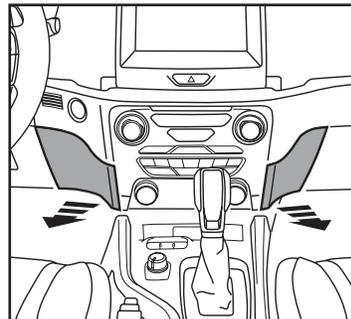

(Figure C)

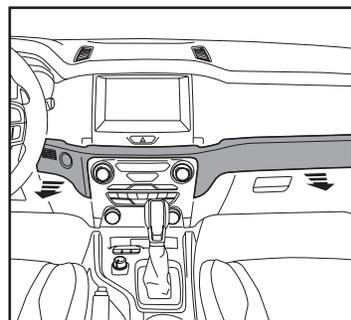

(Figure D)

DASH DISASSEMBLY (CONT.)

- Remove (2) 9/32" screws securing the power port panel, then unclip, unplug, and remove the panel. (Figure E)
- Remove (6) 9/32" screws securing the radio & climate control panel, then unplug and remove. (Figure F)

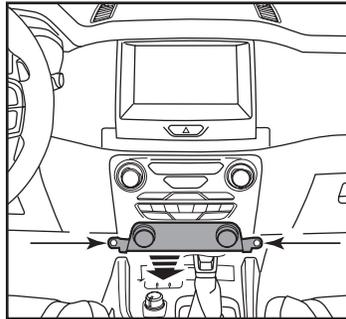

(Figure E)

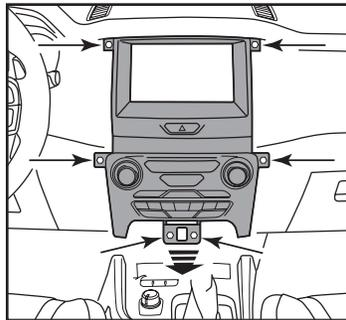

(Figure F)

- Remove (4) 9/32" screws securing the radio display, then unplug and remove. (Figure G)
- Remove (4) 9/32" screws securing the radio chassis. Slide the chassis out, then unplug and remove. (Figure H)

Continue to Kit Assembly

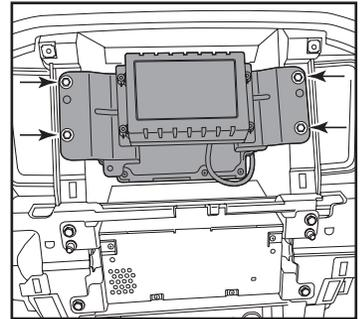

(Figure G)

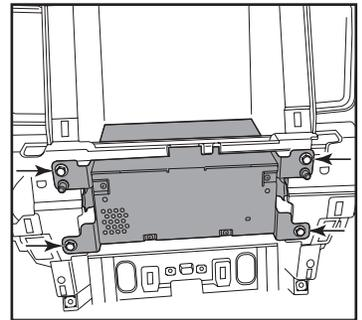

(Figure H)

DASH DISASSEMBLY

Ford Super Duty 2013-2016

1. Unclip and remove the power outlet panel and the blank panel on the left and right side of the radio trim panel. (Figure A)
2. Remove the (2) 9/32" screws exposed behind the two panels previously removed.
3. Unclip and remove the entire radio trim panel including the A/C control and vents.
4. Remove (4) 9/32" screws securing the radio.

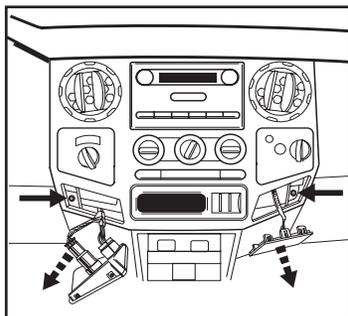

(Figure A)

Continue to Kit Assembly

Ford Super Duty 2017-2022

1. **For vehicles with a center channel speaker:** Unclip and remove the speaker grille in the center of the dash above the radio/climate control panel, and then remove the (2) 9/32" screws exposed. (Figure A)
2. **For vehicles without a center channel speaker:** Remove the rubber pad in the shallow pocket above the radio/climate control panel, and then remove the (2) 9/32" screws exposed. (Figure B)
3. Unclip and remove the panel above the radio/climate control panel, and then remove the (2) 9/32" screws from the top of the radio/climate control panel. (Figure C)

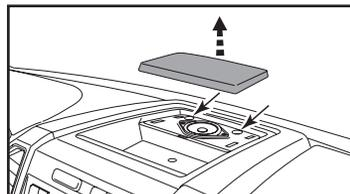

(Figure A)

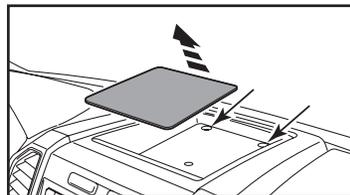

(Figure B)

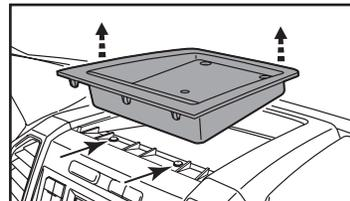

(Figure C)

Continued on the next page

DASH DISASSEMBLY

Ford Super Duty 2017-2022 (cont.)

Ensure that the vehicle is completely off before proceeding onto the following (5) steps

- Using the panel removal tool, carefully unclip, unplug, and remove the radio/climate control panel.
- Remove the 9/32" Phillips screws securing the display screen: (4) for the 4.2-inch display screen models, (6) for 8-inch display screen models, then unplug and remove the screen. (Figure D)(Figure D)
- For models with a 4.2-inch display screen and SYNC®:** Remove (2) 9/32" screws securing the SYNC® module, then unplug and remove. (Figure E)

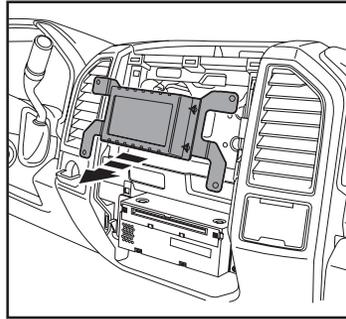

(Figure D)

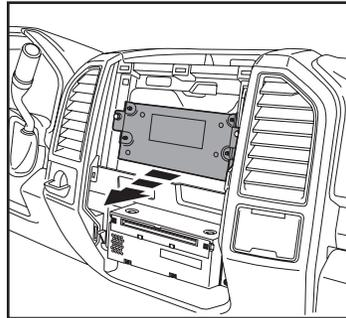

(Figure E)

- Remove (4) 9/32" screws securing the radio chassis, disconnect the wiring, and then remove the factory radio. (Figure F)
- For models equipped with a factory backup camera:** Remove the (2) 10mm nuts located at the top of the camera module. Loosen the bottom nut and reposition the module down onto the lower stud, then re-secure using just (1) 10mm nut. (Figure G)

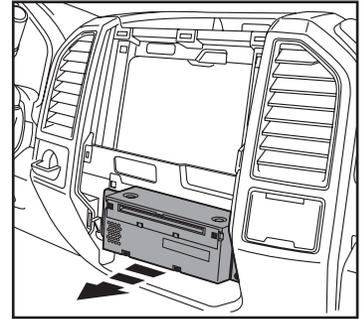

(Figure F)

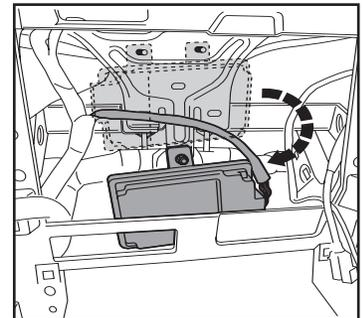

(Figure G)

Continue to Kit Assembly

DASH DISASSEMBLY

Ford Taurus 2013-2019

1. Unclip and remove the (2) trim panels on the left and right side of the center console. (Figure A)
2. Unclip and remove the trim panel to the right of the passenger a/c vent. (Figure B)
3. Unclip and remove the knee bolster trim panel below the steering column. (Figure B)
4. Remove the (1) 9/32" screw from the trim panel to the left of the steering column which has the interior light switch in it.

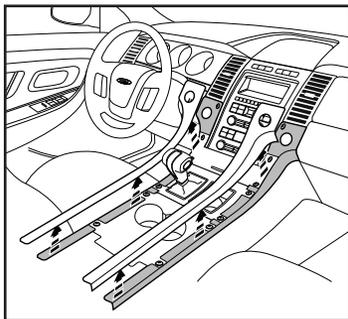

(Figure A)

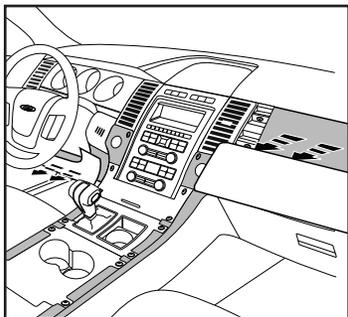

(Figure B)

5. Unclip and remove the trim panel between the steering column and the key cylinder, and then remove the (1) 9/32" screw exposed. (Figure C)
6. Unclip and remove the gauge cluster trim panel. (Figure D)
7. Unclip and remove the trim-panel/speaker-grill above the radio/climate control panel. (Figure D)
8. Remove the (4) 9/32" screws securing the cup holder trim panel, and then unclip and remove. (Figure E)

Continued on the next page

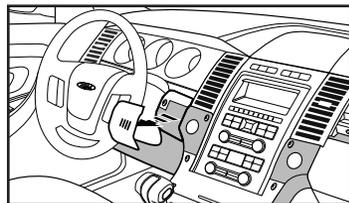

(Figure C)

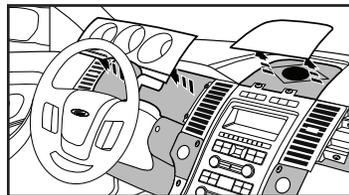

(Figure D)

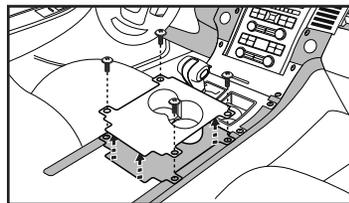

(Figure E)

DASH DISASSEMBLY (CONT.)

9. Remove the (4) 9/32" screws securing the shifter trim panel, and then slide it backwards. (Figure F)

Note: There is no need to remove this panel completely.

10. Remove the (4) 9/32" screws securing the ashtray assembly, and then unclip and remove. (Figure G)

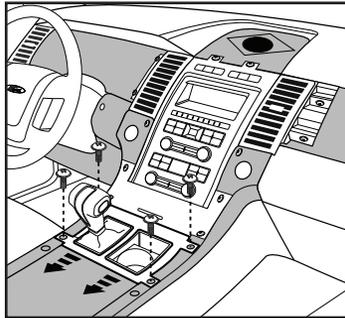

(Figure F)

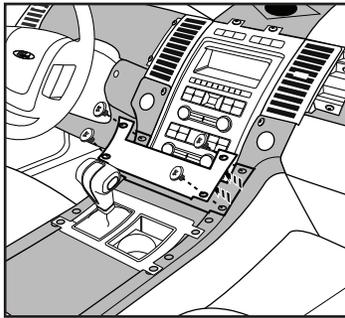

(Figure G)

11. Remove the (10) 9/32" screws securing the radio/climate control panel, and then unclip and remove. (Figure H)
12. Remove the (4) 9/32" screws securing the display screen, and then remove. (Figure I)
13. Remove the (4) 9/32" screws securing the radio chassis, and then remove. (Figure I)

Continue to Kit Preparation

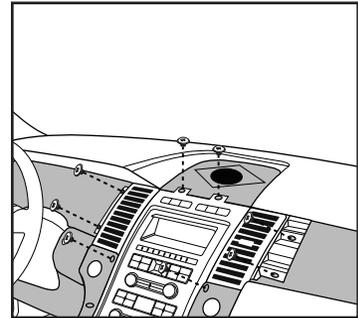

(Figure H)

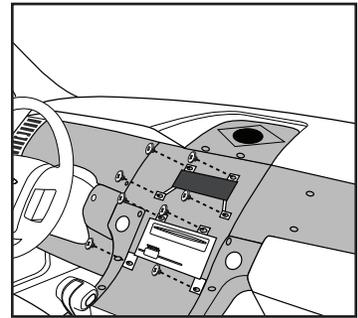

(Figure I)

KIT ASSEMBLY, BRACKET 1

Applications

Edge	2011-2020
Explorer	2011-2019
Super Duty	2013-2022
F-150	2013-2014
Flex	2013-2019
Taurus	2013-2019

Vehicle specific notes

F-150 2013-2014: Bottom mounting tabs on screen use the top tabs on the radio chassis brackets. There is no mounting spot in dash for the bottom tabs in the sub dash. Radio chassis brackets have mounting tabs attached to them for the bottom two mounts of the screen. Customer can take brackets off the radio chassis and mount in dash and still mount the screen and have room for the chassis.

Flex 2013-2019: Shallow mount radio requires dash cut. For Pioneer modular radio use **bracket 1** for the screen and **bracket B** for the chassis

Taurus 2013-2019: Chassis must be mounted in the top mounting position.

Super Duty 2017-2019: For Pioneer modular radio use **bracket 1** for the screen and **bracket A** for the chassis

L-Shape DDIN radio:

1. Attach the **radio brackets** to the **radio trim panel** using the (4) #8 x 3/8" Phillips screws provided. (Figure A)
 2. Slide the radio into the completed assembly and secure it to the assembly using the screws supplied with the radio. (Figure B)
 3. Remove the factory brackets from the 8" screen and assemble to the radio and bracket assembly using the factory hardware. (Figure C)
- Note:** F-150 factory radio brackets shown, other brackets will be different, but similar. The procedure is the same.
4. Locate the factory wiring harness and antenna connector in the dash. Complete all necessary connections to the radio and vehicle. Metra recommends using the proper mating adapter from Metra or AXCESS. Test the radio and vehicle for proper operation.
 5. Reassemble the dash in reverse order of disassembly.

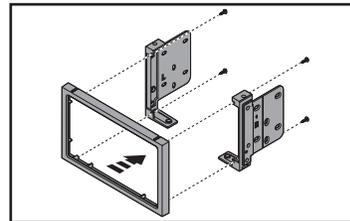

(Figure A)

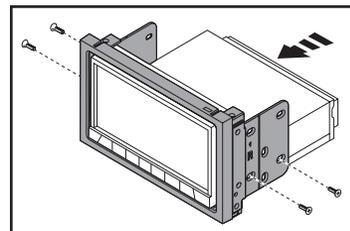

(Figure B)

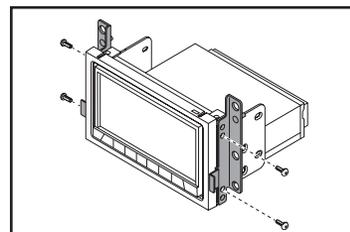

(Figure C)

KIT ASSEMBLY, BRACKET 1 (CONT.)

Shallow DDIN radio:

Note: Radio brackets can be trimmed for clearance if needed. (See detail)

1. Attach the **radio brackets** to the **radio trim panel** using the (4) #8 x 3/8" Phillips screws provided. (Figure A)
2. Slide the radio into the completed assembly and secure it to the assembly using the screws supplied with the radio. (Figure B, D)
3. Remove the factory brackets from the 8" screen and assemble to the radio and bracket assembly using the factory hardware. (Figure C, E)

Note: F-150 factory radio brackets shown, other brackets will be different, but similar. The procedure is the same.

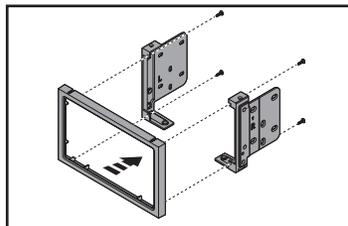

(Figure A)

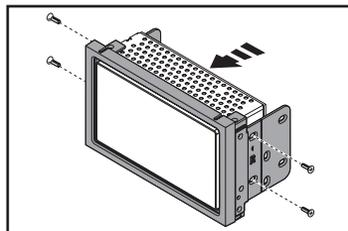

(Figure B)

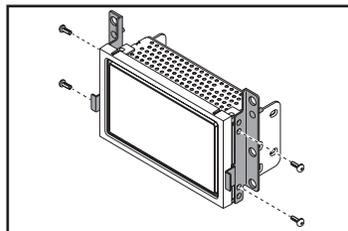

(Figure C)

4. Locate the factory wiring harness and antenna connector in the dash. Complete all necessary connections to the radio and vehicle. Metra recommends using the proper mating adapter from Metra or AXCESS. Test the radio and vehicle for proper operation.
5. Reassemble the dash in reverse order of disassembly.

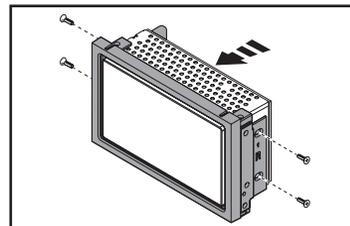
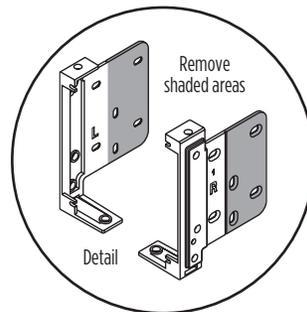

(Figure D)

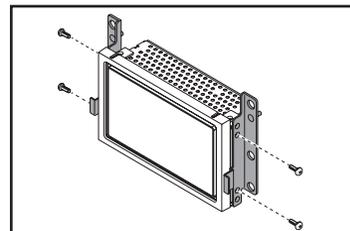

(Figure E)

KIT ASSEMBLY, BRACKET 1 (CONT.)

Pioneer Modular radio

1. Attach the **screen brackets** to the **radio screen** using (6) of the screws provided with the radio. (Figure A)
2. Slide the radio screen into the **radio trim panel**. Attach the **radio brackets** to the **radio trim panel** using (4) of the #8 x 3/8" Phillips screws provided.
Note: the screws go through the radio brackets and the screen brackets, then into the radio trim panel. (Figure B)
3. Slide the radio chassis into the completed assembly and secure with the screws provided with the radio.
Note: the radio chassis may be mounted horizontally or vertically as needed. (Figures C, D)

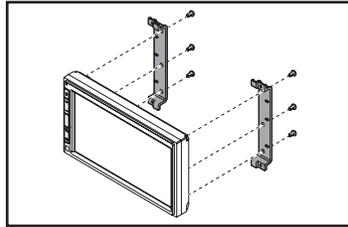

(Figure A)

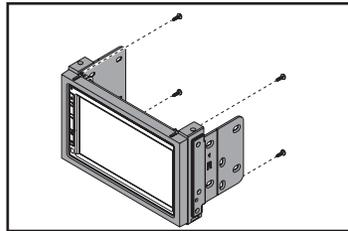

(Figure B)

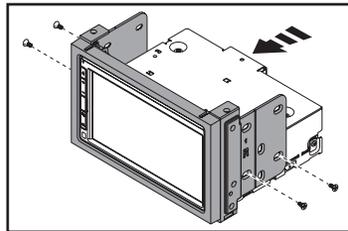

(Figure C)

4. Remove the factory brackets from the 8" screen and assemble to the radio and bracket assembly using the factory hardware. (Figure E, F)
Note: F-150 factory radio brackets shown, other brackets will be different, but similar. The procedure is the same.
5. Locate the factory wiring harness and antenna connector in the dash. Complete all necessary connections to the radio and vehicle. Metra recommends using the proper mating adapter from Metra or AXCESS. Test the radio and vehicle for proper operation.
6. Reassemble the dash in reverse order of disassembly.

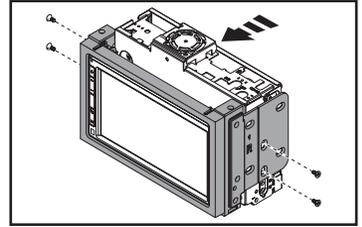

(Figure D)

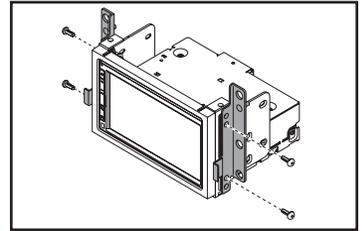

(Figure E)

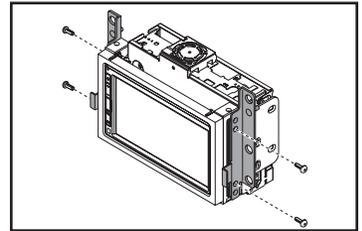

(Figure F)

KIT ASSEMBLY, BRACKET 1 (CONT.)

Pioneer Modular radio Super Duty 2017-2019

Note: Radio brackets can be trimmed for clearance if needed. (See detail)

1. Attach the **screen brackets** to the **radio screen** using (6) of the screws provided with the radio. (Figure A)
2. Slide the radio screen into the **radio trim panel**. Attach **radio brackets** to the **radio trim panel** using (4) of the #8 x 3/8" Phillips screws provided.

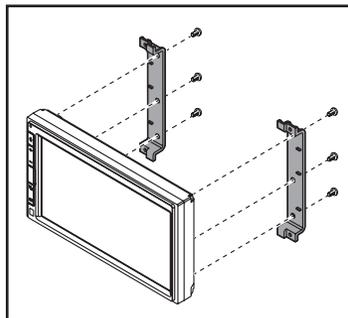

(Figure A)

3. Remove the factory brackets from the 8" screen and assemble to the screen and bracket assembly using the factory hardware. (Figure C)

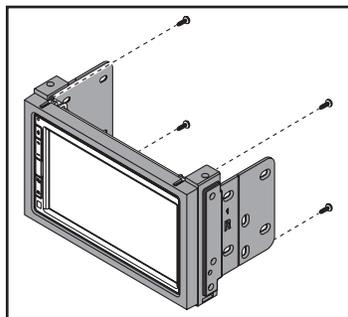

(Figure B)

Note: F-150 factory radio brackets shown, other brackets will be different, but similar. The procedure is the same.

4. Attach **radio brackets A** to the radio chassis using the screws provided with the radio. (Figure D)
5. Locate the factory wiring harness and antenna connector in the dash. Complete all necessary connections to the radio and vehicle. Metra recommends using the proper mating adapter from Metra or AXXESS. Test the radio and vehicle for proper operation.
6. Reassemble the dash in reverse order of disassembly.

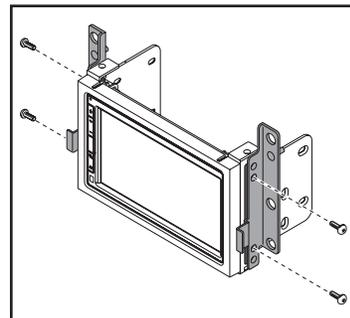
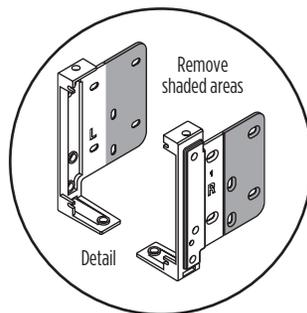

(Figure C)

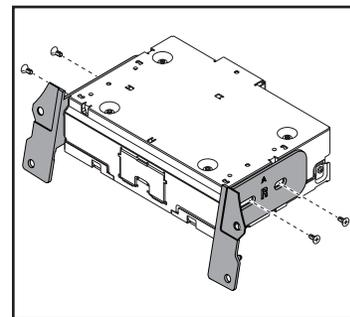

(Figure D)

KIT ASSEMBLY, BRACKET 1 (CONT.)

Pioneer Modular radio

Flex 2013-2019

Note: Radio brackets can be trimmed for clearance if needed. (See detail)

1. Attach the **screen brackets** to the **radio screen** using (6) of the screws provided with the radio. (Figure A)
2. Slide the radio screen into the **radio trim panel**. Attach **radio brackets** to the **radio trim panel** using (4) of the #8 x 3/8" Phillips screws provided.

Note: the screws go through the radio brackets and the screen brackets, then into the radio trim panel. (Figure B)

3. Remove the factory brackets from the 8" screen and assemble to the screen and bracket assembly using the factory hardware. (Figure C)

Note: F-150 factory radio brackets shown, other brackets will be different, but similar. The procedure is the same.

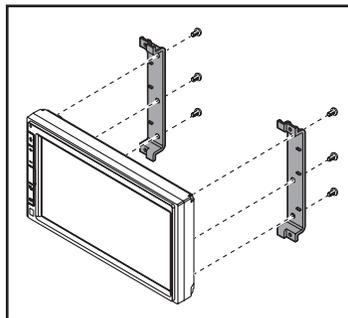

(Figure A)

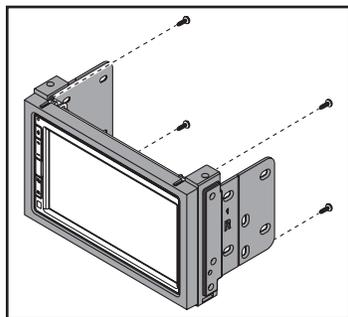

(Figure B)

3. Attach **radio brackets B** to the radio chassis using the screws provided with the radio. (Figure D)
4. Locate the factory wiring harness and antenna connector in the dash. Complete all necessary connections to the radio and vehicle. Metra recommends using the proper mating adapter from Metra or AXXESS. Test the radio and vehicle for proper operation.
5. Reassemble the dash in reverse order of disassembly.

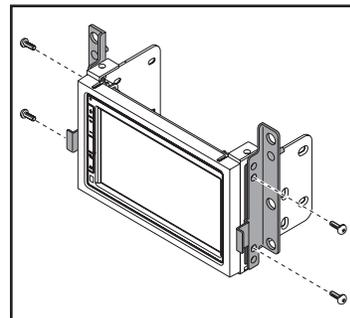
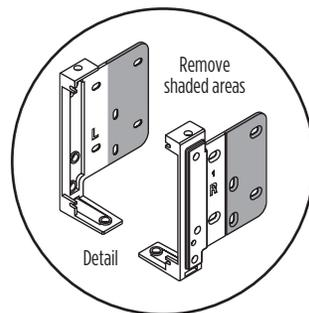

(Figure C)

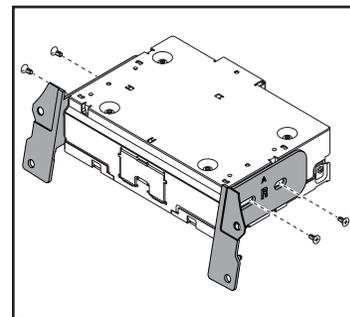

(Figure D)

KIT ASSEMBLY, BRACKET 2

Applications

Expedition	2015-2021
F-150.....	2015-2020
Fusion	2013-2022
Mustang.....	2015-2022
Ranger	2019-2021
Focus	2012-2018
Escape	2013-2019

Vehicle specific notes

Expedition 2015-2019: Use vertical mount Pioneer chassis.

F-150 2015-2020: Use vertical mount Pioneer chassis.

Escape 2013-2019: Shallow mount radio requires dash cut.

L-Shape DDIN radio:

1. Attach the **radio brackets** to the **radio trim panel** using the (4) #8 x 3/8" Phillips screws provided. (Figure A)
 2. Slide the radio into the completed assembly and secure it to the assembly using the screws supplied with the radio. (Figure B)
 3. Remove the factory brackets from the 8" screen and assemble to the radio and bracket assembly using the factory hardware. (Figure C)
- Note:** F-150 factory radio brackets shown, other brackets will be different, but similar. The procedure is the same.
4. Locate the factory wiring harness and antenna connector in the dash. Complete all necessary connections to the radio and vehicle. Metra recommends using the proper mating adapter from Metra or AXCESS. Test the radio and vehicle for proper operation.
 5. Reassemble the dash in reverse order of disassembly.

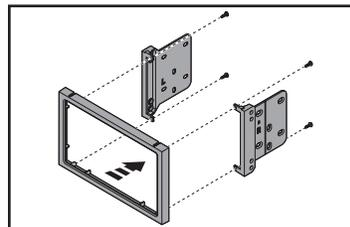

(Figure A)

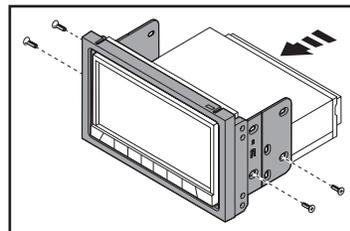

(Figure B)

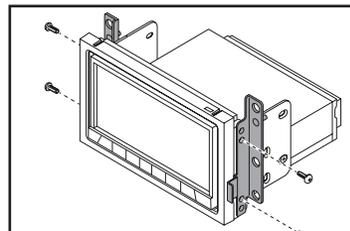

(Figure C)

KIT ASSEMBLY, BRACKET 2 (CONT.)

Shallow DDIN radio:

Note: Radio brackets can be trimmed for clearance if needed. (See detail)

1. Attach the **radio brackets** to the **radio trim panel** using the (4) #8 x 3/8" Phillips screws provided. (Figure B)
2. Slide the radio into the completed assembly and secure it to the assembly using the screws supplied with the radio. (Figure B, D)
3. Remove the factory brackets from the 8" screen and assemble to the radio and bracket assembly using the factory hardware. (Figure C, E)

Note: F-150 factory radio brackets shown, other brackets will be different, but similar. The procedure is the same.

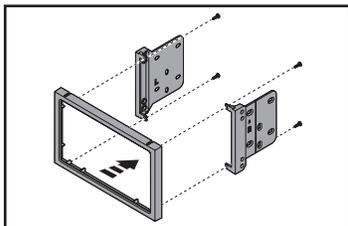

(Figure A)

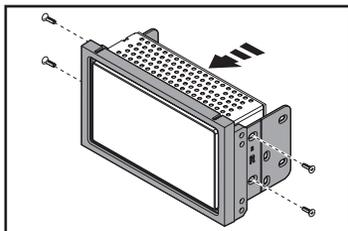

(Figure B)

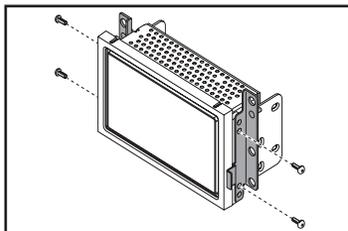

(Figure C)

4. Locate the factory wiring harness and antenna connector in the dash. Complete all necessary connections to the radio and vehicle. Metra recommends using the proper mating adapter from Metra or AXCESS. Test the radio and vehicle for proper operation.
5. Reassemble the dash in reverse order of disassembly.

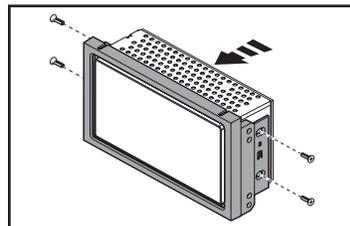
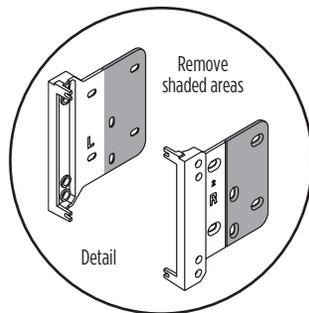

(Figure D)

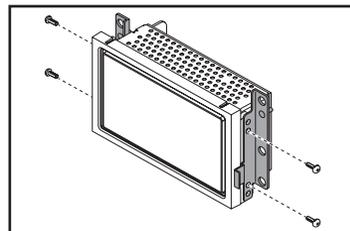

(Figure E)

KIT ASSEMBLY, BRACKET 2 (CONT.)

Pioneer Modular radio

1. Attach the **screen brackets** to the **radio screen** using (6) of the screws provided with the radio. (Figure A)
2. Slide the radio screen into the **radio trim panel**. Attach the **radio brackets** to the **radio trim panel** using (4) of the #8 x 3/8" Phillips screws provided.
Note: the screws go through the radio brackets and the screen brackets, then into the radio trim panel. (Figure B)
3. Slide the radio chassis into the completed assembly and secure with the screws provided with the radio.
Note: the radio chassis may be mounted horizontally or vertically as needed. (Figures C, D)

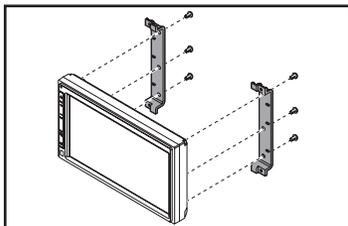

(Figure A)

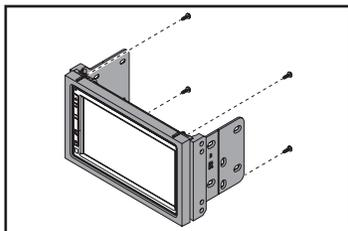

(Figure B)

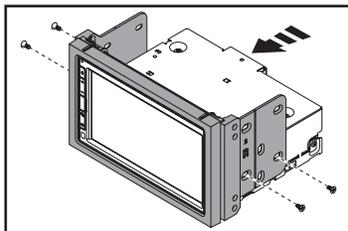

(Figure C)

4. Remove the factory brackets from the 8" screen and assemble to the radio and bracket assembly using the factory hardware. (Figure E, F)

Note: F-150 factory radio brackets shown, other brackets will be different, but similar. The procedure is the same.

4. Locate the factory wiring harness and antenna connector in the dash. Complete all necessary connections to the radio and vehicle. Metra recommends using the proper mating adapter from Metra or AXCESS. Test the radio and vehicle for proper operation.
5. Reassemble the dash in reverse order of disassembly.

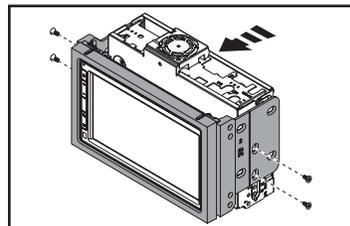

(Figure D)

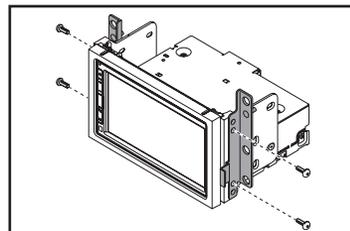

(Figure E)

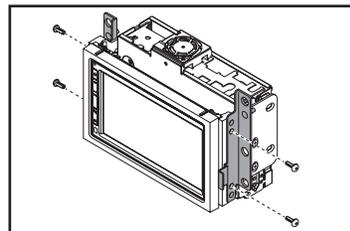

(Figure F)

KIT ASSEMBLY, BRACKET 2 (CONT.)

Pioneer Modular radio

Mustang 2015-2019

Note: Radio brackets can be trimmed for clearance if needed. (See detail)

1. Attach the **screen brackets** to the **radio screen** using (6) of the screws provided with the radio. (Figure A)
2. Slide the radio screen into the **radio trim panel**. Attach **radio brackets** to the **radio trim panel** using (4) of the #8 x 3/8" Phillips screws provided.

Note: the screws go through the radio brackets and the screen brackets, then into the radio trim panel. (Figure B)

3. Remove the factory brackets from the 8" screen and assemble to the screen and bracket assembly using the factory hardware. (Figure C)

Note: F-150 factory radio brackets shown, other brackets will be different, but similar. The procedure is the same.

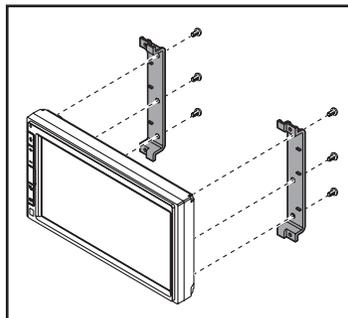

(Figure A)

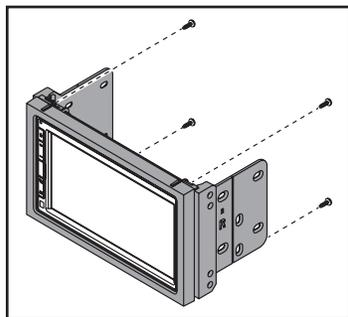

(Figure B)

4. Attach **radio brackets C** to the radio chassis using the screws provided with the radio. (Figure D)
5. Locate the factory wiring harness and antenna connector in the dash. Complete all necessary connections to the radio and vehicle. Metra recommends using the proper mating adapter from Metra or AXXESS. Test the radio and vehicle for proper operation.
6. Reassemble the dash in reverse order of disassembly.

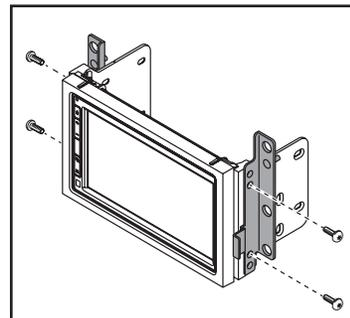
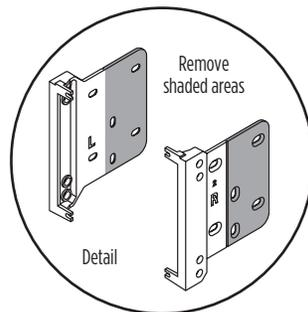

(Figure C)

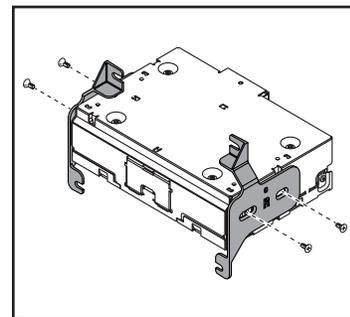

(Figure D)

KIT ASSEMBLY, BRACKET 3

Applications

Ranger2022-2023

L-Shape DDIN radio:

1. Attach the **radio brackets** to the **radio trim panel** using the (4) #8 x 3/8" Phillips screws provided. (Figure A)
2. Slide the radio into the completed assembly and secure it to the assembly using the screws supplied with the radio. (Figure B)
3. Locate the factory wiring harness and antenna connector in the dash. Complete all necessary connections to the radio and vehicle. Metra recommends using the proper mating adapter from Metra or AXCESS. Test the radio and vehicle for proper operation.
4. Reassemble the dash in reverse order of disassembly.

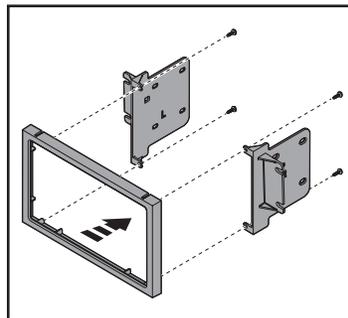

(Figure A)

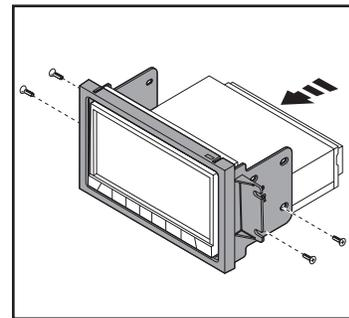

(Figure B)

KIT ASSEMBLY, BRACKET 3 (CONT.)

Shallow DDIN radio:

1. Attach the **radio brackets** to the **radio trim panel** using the (4) #8 x 3/8" Phillips screws provided. (Figure B)
2. Slide the radio into the completed assembly and secure it to the assembly using the screws supplied with the radio. (Figure B)
3. Locate the factory wiring harness and antenna connector in the dash. Complete all necessary connections to the radio and vehicle. Metra recommends using the proper mating adapter from Metra or AXCESS. Test the radio and vehicle for proper operation.
4. Reassemble the dash in reverse order of disassembly.

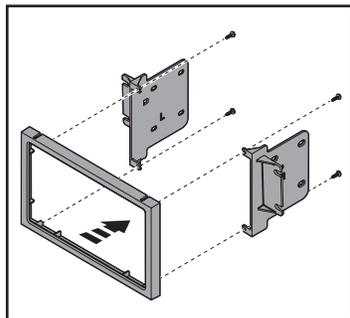

(Figure A)

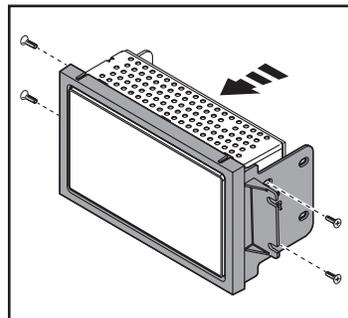

(Figure B)

KIT ASSEMBLY, BRACKET 3 (CONT.)

Pioneer Modular radio

1. Attach the **screen brackets** to the **radio screen** using (6) of the screws provided with the radio. (Figure A)
2. Slide the radio screen into the **radio trim panel**. Attach the **radio brackets** to the **radio trim panel** using (4) of the #8 x 3/8" Phillips screws provided. **Note:** the screws go through the radio brackets and the screen brackets, then into the radio trim panel. (Figure B)
3. Slide the radio chassis into the completed assembly and secure with the screws provided with the radio.

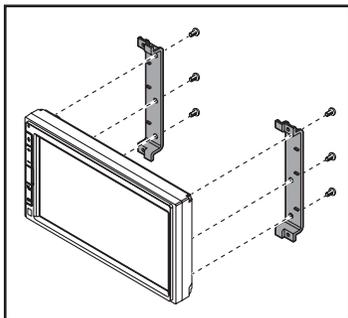

(Figure A)

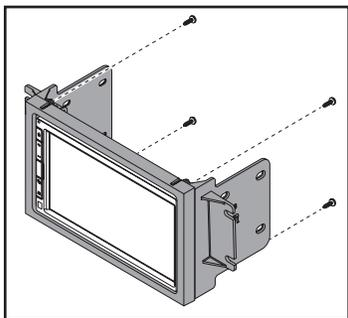

(Figure B)

4. Locate the factory wiring harness and antenna connector in the dash. Complete all necessary connections to the radio and vehicle. Metra recommends using the proper mating adapter from Metra or AXXESS. Test the radio and vehicle for proper operation.
5. Reassemble the dash in reverse order of disassembly.

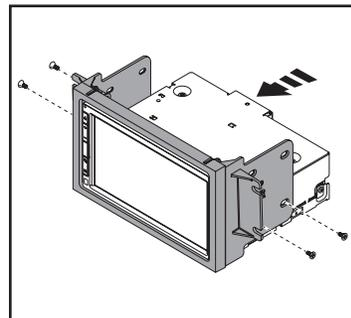

(Figure C)



107-FD11

INSTALLATION INSTRUCTIONS



Having difficulties? We're here to help.



Contact our Tech Support line at:

386-257-1187



Or via email at:

techsupport@metra-autosound.com

Tech Support Hours (Eastern Standard Time)

Monday - Friday: 9:00 AM - 7:00 PM

Saturday: 10:00 AM - 5:00 PM

Sunday: 10:00 AM - 4:00 PM



**Metra recommends MECP
certified technicians**