



INSTALLATION INSTRUCTIONS FOR PART 95-5819

Ford F-150 2009-up *(only XL models without plus package)* **95-5819**

KIT FEATURES

- Double DIN radio provision



KIT COMPONENTS

- A) Double DIN radio housing • B) Double DIN brackets

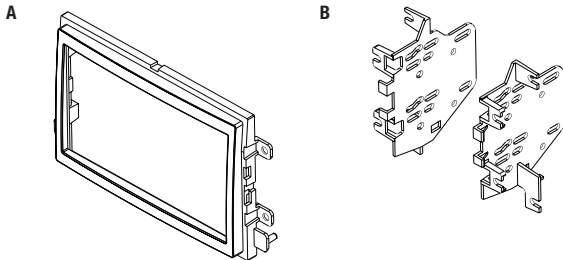

WIRING & ANTENNA CONNECTIONS *(sold separately)*

Wiring Harness:

- 70-5520 - Ford 2003-up

Antenna Adapter:

- 40-CR10 - Chrysler 2002-up

TOOLS REQUIRED

- Cutting tool • Phillips screwdriver
- Socket wrench

CAUTION: *Metra recommends disconnecting the negative battery terminal before beginning any installation. All accessories, switches, and especially air bag indicator lights must be plugged in before reconnecting the battery or cycling the ignition.*

NOTE: *Refer to the instructions included with the aftermarket radio.*

Table of Contents

Dash Disassembly

– Ford F-150 2009-up (only XL models without plus package)..... 2-3

Kit Assembly

– Double DIN radio provision3

Ford F-150 2009-up

(only XL models without plus package)

1. Unclip and remove the switch panel to the right of the cigarette lighter then remove the (1) 9/32" screw exposed. (Figure A)
2. Remove the rubber pad at the top of the radio trim panel then remove the (2) 9/32" screws exposed. (Figure B)
3. Remove (4) 10 mm hex head screws securing the factory radio. Unplug wiring and remove radio.

Continue on next page

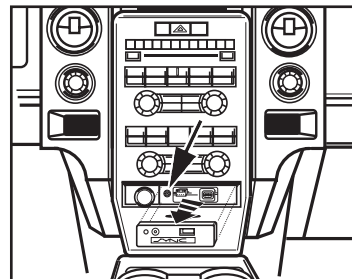

(Figure A)

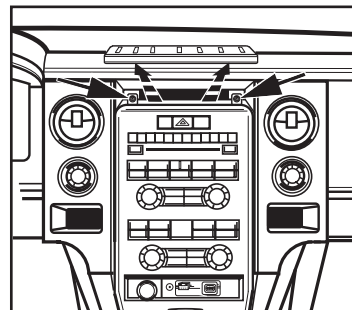

(Figure B)

Ford F-150 2009-up
(only XL models without plus package)

- Unclip and pull the side panels containing the A/C vents away from the radio trim panel. (Figure C)

Note: It is not necessary to remove the panels completely.

- Unclip and remove the radio trim panel. (Figure D)
- Remove (4) 9/32" screws to remove the factory radio.

Continue to kit assembly

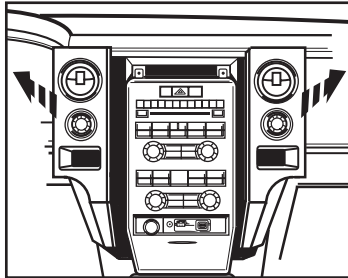

(Figure C)

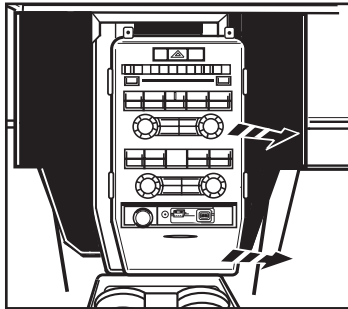

(Figure D)

Double DIN radio provision

- Slide the appropriate side bracket over the mounting legs of the double DIN trim plate aligning the holes in the trim plate and the bracket and rotate inward.

Note: The notch in the housing should be on top. (Figure A)

- Slide the double DIN radio into the bracket/radio housing assembly and secure the double DIN radio to the assembly using the screws supplied with the radio. (Figure B)

Continue on back page

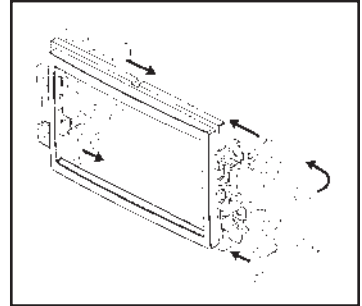

(Figure A)

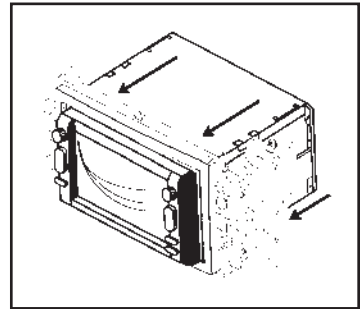

(Figure B)



INSTALLATION INSTRUCTIONS FOR PART 95-5819



Double DIN radio provision

3. Cut and remove half of the top (2) mounting legs with the brackets attached. (Figure C)
4. Locate the factory wiring harness in the dash. Metra recommends using the proper mating adapter from Metra or AXCESS. Re-connect the negative battery terminal and test the unit for proper operation.
5. Reassemble dash in reverse order of disassembly.

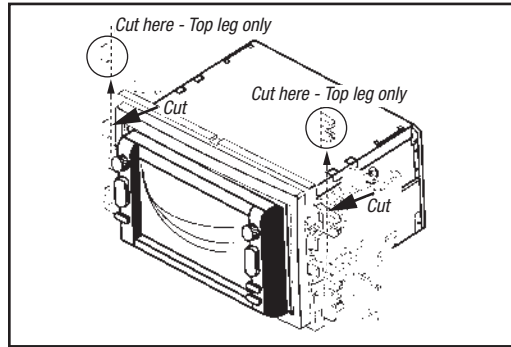

(Figure C)



KNOWLEDGE IS POWER

Enhance your installation and fabrication skills by enrolling in the most recognized and respected mobile electronics school in our industry. Log onto www.installerinstitute.com or call 800-354-6782 for more information and take steps toward a better tomorrow.



Metra recommends MECP certified technicians