



## INSTALLATION INSTRUCTIONS FOR PART 95-7337B

# APPLICATIONS

## Kia Soul 2010-2011

### 95-7337B

#### KIT FEATURES

- Double DIN head unit provision
- Stacked ISO head unit provision
- *Painted matte black*

#### KIT COMPONENTS

- A) Double DIN trim plate • B) Double DIN brackets



A

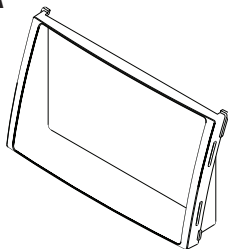

B

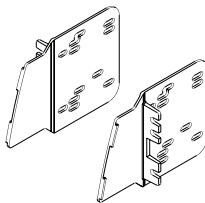

#### WIRING & ANTENNA CONNECTIONS (sold separately)

Wiring Harness:

- 70-7303 - Kia/Hyundai harness for 2009-up vehicles

Antenna Adapter:

- 40-KI11 - Kia antenna adapter for 2007-up vehicles

#### TOOLS REQUIRED

- Panel removal tool • Phillips screwdriver • Small flat blade screwdriver

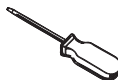
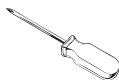

**METRA. THE WORLD'S BEST KITS.™**



**1-800-221-0932**



**metraonline.com**

© COPYRIGHT 2004-2011 METRA ELECTRONICS CORPORATION

REV. 5/22/12 INST95-7337B

REV. 5/22/12



95-7337B

## Table of Contents

### Dash Disassembly

– Kia Soul 2010-2011 ..... 3

### Kit Assembly

– Double DIN head unit provision ..... 4  
– Stacked ISO head unit provision..... 4

**CAUTION:** *Metra recommends disconnecting the negative battery terminal before beginning any installation. All accessories, switches, and especially air bag indicator lights must be plugged in before reconnecting the battery or cycling the ignition.*

**Note:** *Refer to the instructions included with the aftermarket radio.*



### KNOWLEDGE IS POWER

Enhance your installation and fabrication skills by enrolling in the most recognized and respected mobile electronics school in our industry. Log onto [www.installerinstitute.com](http://www.installerinstitute.com) or call 800-354-6782 for more information and take steps toward a better tomorrow.



**Metra recommends MECP certified technicians**

## Kia Soul 2010-2011

1. Unclip and remove the radio/climate control trim panel. (Figure A)
2. Remove (4) Phillips screws securing the climate control. (Figure B)
3. Remove (4) Phillips screws securing the radio. (Figure C)

*Continue to kit assembly*

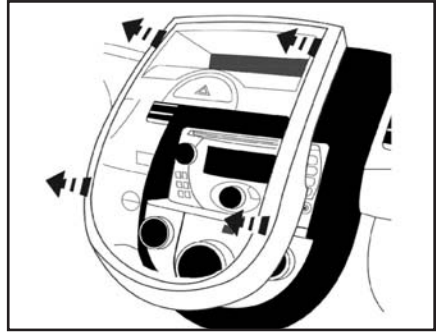

(Figure A)

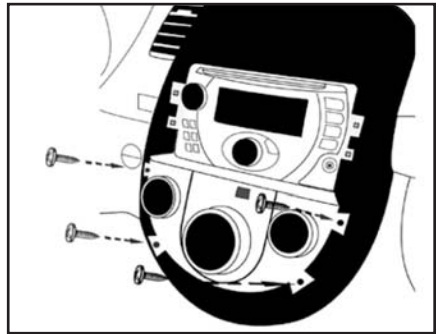

(Figure B)

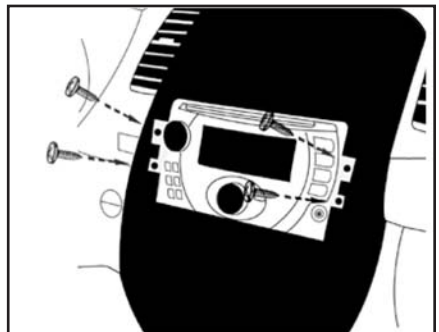

(Figure C)



## Kit Assembly 95-7337B

### Double DIN/Stacked ISO head unit provision

1. Locate the factory wiring harness in the dash. Metra recommends using the proper mating adapter from Metra or AXXESS. Re-connect the negative battery terminal and test the unit for proper operation.
2. Attach the Double DIN brackets to the Double DIN Trim Plate. (Figure A)
3. Slide the radio into the bracket/radio housing assembly and secure using the screws supplied with the radio. (Figure B)
4. Reassemble dash in reverse order of disassembly.

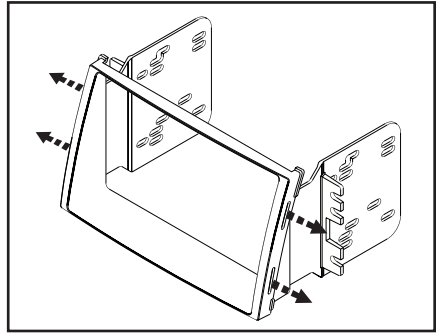

(Figure A)

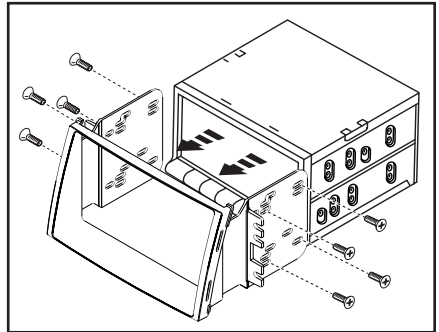

(Figure B)









## INSTALLATION INSTRUCTIONS FOR PART 95-7337B

REV. 5/22/12 INST95-7337B



**1-800-221-0932**



**metraonline.com**

© COPYRIGHT 2004-2011 METRA ELECTRONICS CORPORATION





## INSTRUCCIONES DE INSTALACIÓN PARA LA PIEZA 95-7337B

### APLICACIONES

# Kia Soul 2010-2011

## 95-7337B

### CARACTERÍSTICAS DEL KIT

- Provisión de unidad central doble DIN
- Provisión de unidad central ISO vertical
- *Pintada en negro mate*

### COMPONENTES DEL KIT

- A) Placa de moldura doble DIN • B) Soportes doble DIN



A

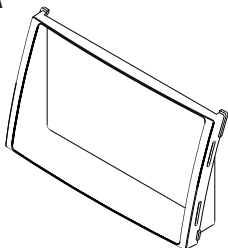

B

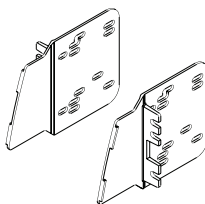

### CABLEADO Y CONEXIONES DE ANTENA (se venden por separado)

Arnés de cableado:

- 70-7303 - Arnés para Kia/Hyundai 2009 y más recientes

Adaptador de antena:

- 40-K111 - Adaptador de antena para Kia for 2007 y más recientes

### HERRAMIENTAS REQUERIDAS

- Herramienta de remoción de panel • Destornillador Phillips • Destornillador cabeza plana

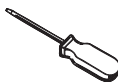
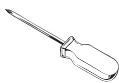
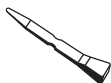

**METRA. THE WORLD'S BEST KITS.™**



**1-800-221-0932**



**metraonline.com**

© COPYRIGHT 2004-2011 METRA ELECTRONICS CORPORATION

INST95-7337B

REV. 5/22/12



95-7337B

## Indice

### Desmontaje del tablero

– Kia Soul 2010-2011 .....	3
----------------------------	---

### Ensamble del kit

– Provisión de unidad central doble DIN .....	4
– Provisión de unidad central ISO vertical .....	4

**PRECAUCIÓN:** *Metra recomienda desconectar el terminal negativo de la batería antes de comenzar cualquier instalación. Todos los accesorios, interruptores y, especialmente, las luces indicadoras de airbag deben estar enchufados antes de volver a conectar la batería o comenzar el ciclo de ignición.*

**Nota:** *Remítase a las instrucciones incluidas con el radio de posventa.*



#### EL CONOCIMIENTO ES PODER

Mejore sus habilidades de instalación y fabricación inscribiéndose en la escuela de dispositivos electrónicos móviles más reconocida y respetada de nuestra industria. Regístrese en [www.installerinstitute.com](http://www.installerinstitute.com) o llame al 800-354-6782 para obtener más información y avance hacia un futuro mejor.



**Metra recomienda técnicos con certificación del Programa de Certificación en Electrónica Móvil (Mobile Electronics Certification Program, MECP).**

## Kia Soul 2010-2011

1. Desenganche y retire radio/panel de control de temperatura. (Figura A)
2. Retire (4) tornillos de cabeza Phillips que sujetan el control de clima. (Figura B)
3. Retire (4) tornillos Phillips asegurar la radio. (Figura C)

*Continuará al ensamble del kit*

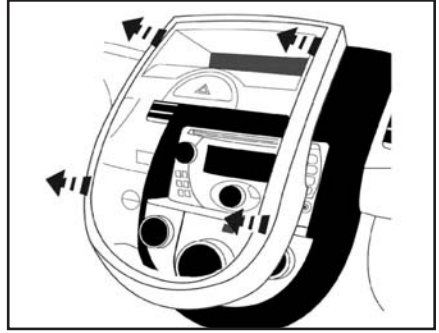

(Figura A)

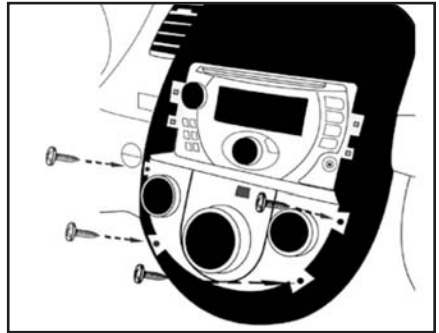

(Figura B)

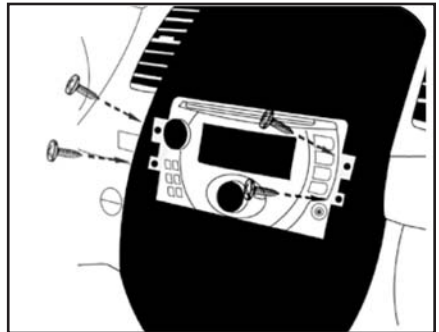

(Figura C)

### Doble DIN/Provisión de unidad central ISO vertical

1. Ubique el arnés del cableado de fábrica en el tablero. Metra recomienda usar el adaptador de acoplamiento adecuado de Metra o AXCESS. Vuelva a conectar el terminal negativo de la batería y pruebe la unidad para verificar que funcione correctamente.
2. Fije los dobles soportes DIN a la placa de moldura doble DIN. (Figura A)
3. Deslice la radio en el conjunto de la carcasa del soporte / radio y asegure con los tornillos suministrados con la radio. (Figura B)
4. Vuelva a montar el tablero en forma inversa al desmontaje.

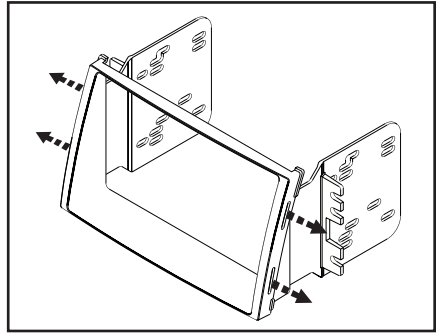

(Figura A)

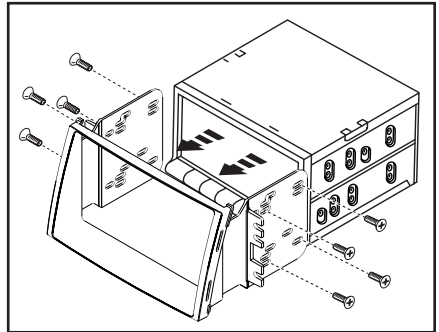

(Figura B)









## INSTRUCCIONES DE INSTALACIÓN PARA LA PIEZA 95-7337B

REV. 5/22/12 INST95-7337B



**1-800-221-0932**



**metraonline.com**

© COPYRIGHT 2004-2011 METRA ELECTRONICS CORPORATION