



Hyundai Veloster 2012-2017

Visit MetraOnline.com for more detailed information about the product and up-to-date vehicle specific applications

KIT FEATURES

- ISO DDIN radio provision
- Painted matte black

KIT COMPONENTS

- A) Radio trim panel • B) Radio brackets

A

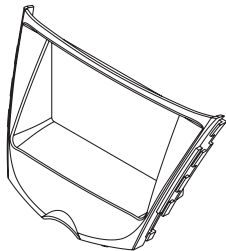

B

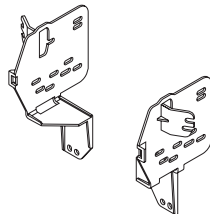

TABLE OF CONTENTS

Dash Disassembly.....	2
Kit Assembly.....	3

WIRING & ANTENNA CONNECTIONS

(sold separately)

Wiring Harness: • 70-7304 - Hyundai/Kia harness 2010-up • HYKIA-01 - Hyundai/Kia amplified system interface.

Antenna Adapter: 40-K111

TOOLS REQUIRED

- Panel removal tool • Phillips screwdriver
- Socket wrench

Attention! With the key out of the ignition, disconnect the negative battery terminal before installing this product. Ensure that all installation connections are secure before cycling the ignition to test this product.

DASH DISASSEMBLY

1. Unclip and remove the climate control/vent panel around the radio. (Figure A)
2. Remove (4) Phillips screws securing the radio. (Figure B)

Continue to Kit Assembly

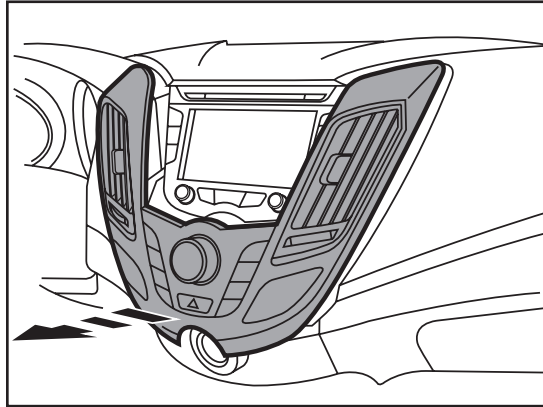

(Figure A)

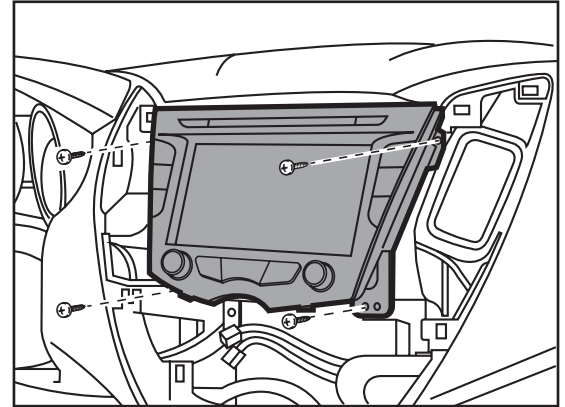

(Figure B)

KIT ASSEMBLY

1. Clip the **radio trim panel** into the climate control/vent panel. (Figure A)
2. Mount the DDIN radio to the **radio brackets** using the screws supplied with the radio. (Figure B)
3. Mount the radio/bracket assembly into the dash.
4. Locate the factory wiring harness and antenna plug in the dash. Metra recommends using the proper mating adapters from Metra and/or AXXESS. Re-connect the negative battery terminal and test the unit for proper operation.
5. Reassemble dash in reverse order of disassembly.

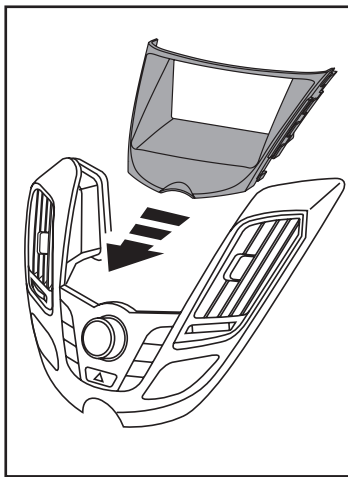

(Figure A)

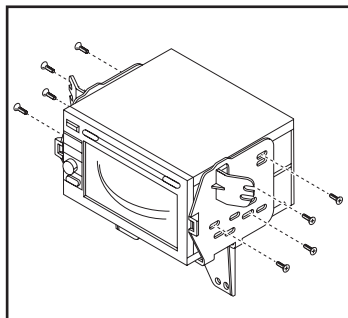

(Figure B)



95-7350B
INSTALLATION INSTRUCTIONS



Having difficulties? We're here to help.



Contact our Tech Support line at:

386-257-1187



Or via email at:

techsupport@metra-autosound.com

Tech Support Hours (Eastern Standard Time)

Monday - Friday: 9:00 AM - 7:00 PM

Saturday: 10:00 AM - 5:00 PM

Sunday: 10:00 AM - 4:00 PM



**Metra recommends MECP
certified technicians**



Hyundai Veloster 2012-2017

Visite MetraOnline.com para más información acerca del producto y las aplicaciones específicas más actualizadas del vehículo

CARACTERÍSTICAS DEL KIT

- Provisión de unidad central ISO DIN con cavidad
- Pintura negro mate

COMPONENTES DEL KIT

- A) Panel de moldura para radio • B) Soportes para radio • C) Cavidad • D) Tornillos Phillips #8 de 3/8" (4)

A

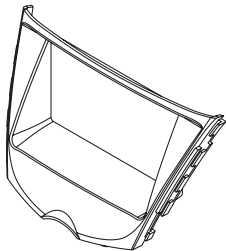

B

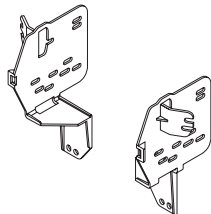

C

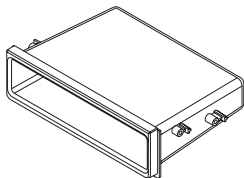

D



INDICE

Desmontaje del tablero	2
Ensamble del kit	3

CABLEADO Y CONEXIONES DE ANTENA

(se venden por separado)

Arnés de cableado: • 70-7304 - Arnés Kia/Hyundai 2010 y más recientes • HYKIA-01 - Hyundai/Kia sistema de amplificación de interfaz
Adaptador de antena: • 40-K111

HERRAMIENTAS NECESARIAS

- Herramienta para quitar paneles
- Destornillador Phillips • Llave para dadose

¡Atención! Con la llave fuera del encendido, desconecte el terminal negativo de la batería antes de instalar este producto. Asegúrese de que todas las conexiones de la instalación estén seguras antes de encender y apagar el encendido para probar este producto.

DESMONTAJE DEL TABLERO

1. Desenganche y quite el control de clima/panel de ventilación que rodea el radio. (Figura A)
2. Quite los (4) tornillos Phillips que sostienen el radio. (Figura B)

Continúe con el ensamble del kit

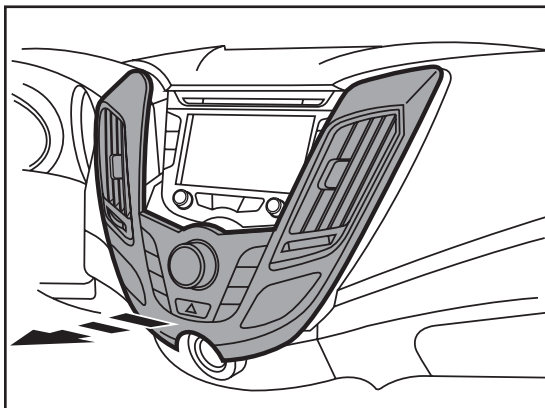

(Figura A)

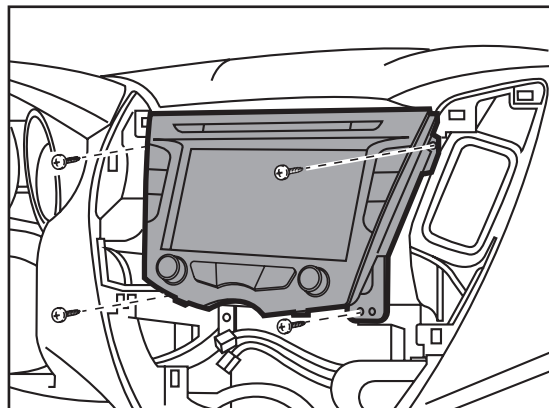

(Figura B)

ENSAMBLE DEL KIT

1. Enganche el **panel de la moldura del radio** en el panel de control de clima/ventilación. (Figura A)
2. Monte la **cavidad** en los **soportes del radio** con los (4) tornillos Phillips #8 de 3/8" suministrados. (Figura B)
3. Deslice la unidad central en los soportes del radio y sujétela con los tornillos suministrados con la unidad. (Figura C)
4. Ubique el arnés de cableado de fábrica y el conector de la antena en el tablero. Metra recomienda que use adaptadores adecuados de acoplamiento de Metra y/o de AXCESS. Vuelva a conectar la terminal negativa de la batería y pruebe la unidad para verificar que funcione correctamente.
5. Vuelva a armar el tablero al revés de como lo desarmó.

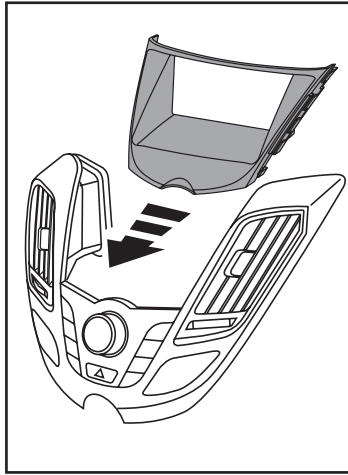

(Figura A)

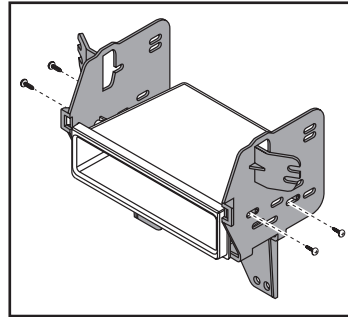

(Figura B)

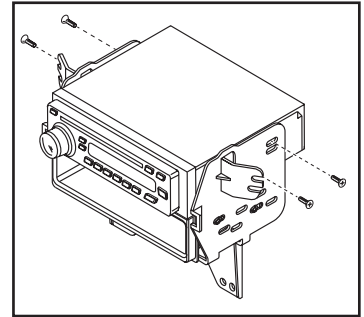

(Figura C)



99-7350B
INSTRUCCIONES DE INSTALACIÓN



¿Tienes dificultades? Estamos aquí para ayudar.



Póngase en contacto con nuestra
línea de soporte técnico en:
386-257-1187



O por correo electrónico a:
techsupport@metra-autosound.com

Horas de soporte técnico (hora estándar del este)

Monday - Friday: 9:00 AM - 7:00 PM

Saturday: 10:00 AM - 5:00 PM

Sunday: 10:00 AM - 4:00 PM



**Metra recomienda MECP
técnicos certificados**