



### Toyota C-HR 2018

Visit [MetraOnline.com](http://MetraOnline.com) for more detailed information about the product and up-to-date vehicle specific applications

#### KIT FEATURES

- ISO DDIN radio provision
- Painted high gloss black

#### KIT COMPONENTS

- A) Radio housing trim panel • B) Radio brackets • C) (4) #6 x 3/8" Phillips screws

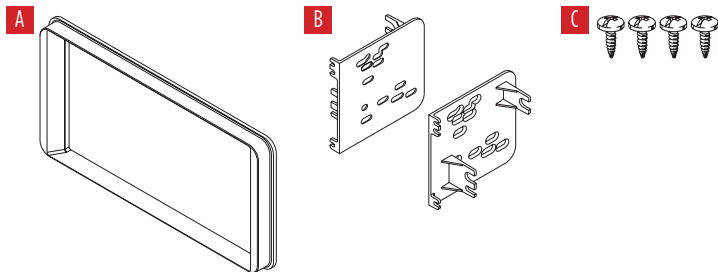

#### TABLE OF CONTENTS

Dash Disassembly .....	2
Kit Assembly .....	3

#### WIRING & ANTENNA CONNECTIONS (sold separately)

Wiring Harness: 70-1761

Antenna Adapter: 40-LX10

#### TOOLS REQUIRED

- Panel removal tool • Phillips screwdriver
- 10mm socket wrench

**Attention!** With the key out of the ignition, disconnect the negative battery terminal before installing this product. Ensure that all installation connections are secure before cycling the ignition to test this product.

## DASH DISASSEMBLY

1. Unclip and remove the trim panel from around the factory radio, including the clock. (Figure A)
2. Remove (4) 10mm bolts securing the radio, then remove it. (Figure B)

*Continue to Kit Assembly*

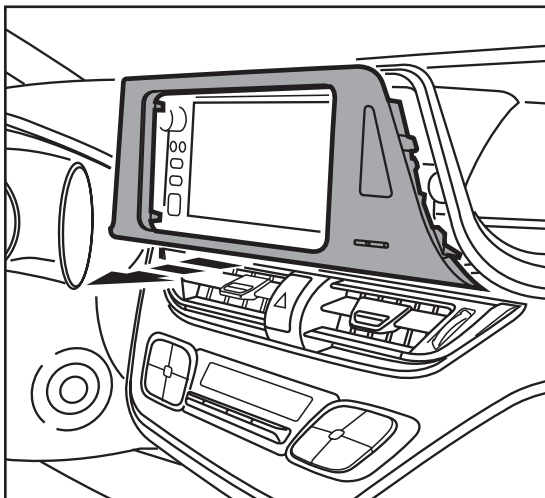

(Figure A)

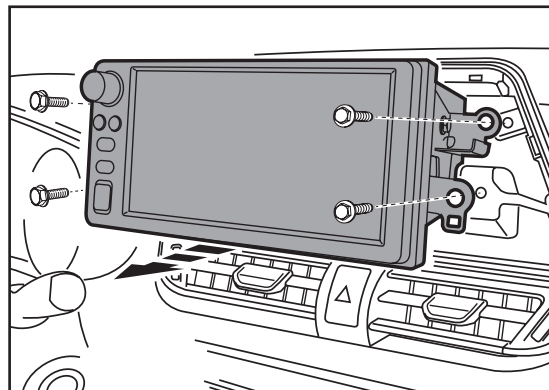

(Figure B)

## KIT ASSEMBLY

1. **Attach the radio brackets** to the **radio housing trim panel** using the (4) #6 x 3/8" screws supplied. (Figure A)
2. Slide the radio into the assembly and secure with the screws supplied with the radio. (Figure B)
4. Locate the factory wiring harness and antenna plug in the dash and make all necessary wire connections to the radio. Metra recommends using the proper mating adapters from Metra and/or AXXESS. Test the radio for proper operation.
5. Mount the new radio assembly into the dash.
6. Reassemble the dash in the reverse order of disassembly.

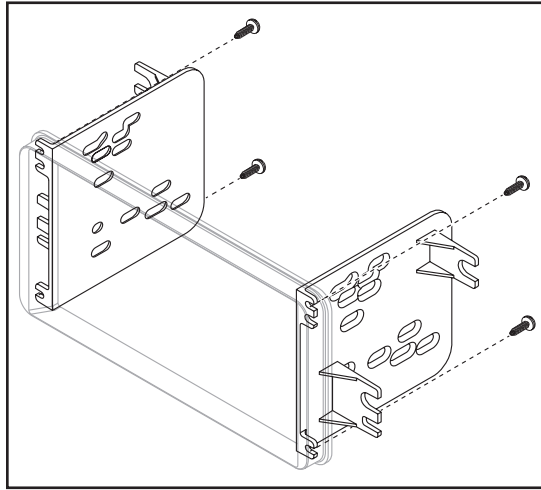

(Figure A)

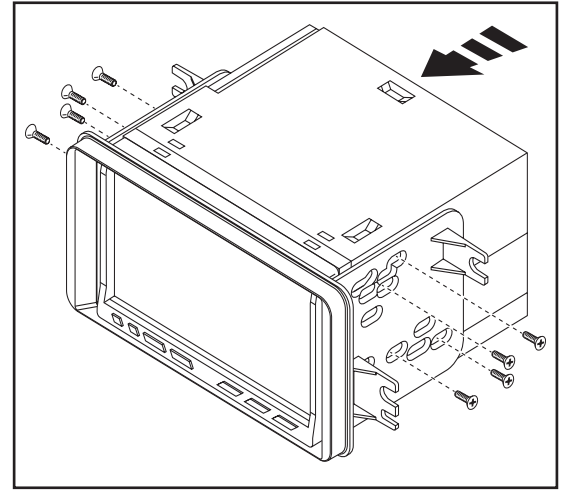

(Figure B)



**95-8265HG**  
INSTALLATION INSTRUCTIONS



Having difficulties? We're here to help.



Contact our Tech Support line at:

**386-257-1187**



Or via email at:

[techsupport@metra-autosound.com](mailto:techsupport@metra-autosound.com)

**Tech Support Hours (Eastern Standard Time)**

Monday - Friday: 9:00 AM - 7:00 PM

Saturday: 10:00 AM - 7:00 PM

Sunday: 10:00 AM - 4:00 PM



**KNOWLEDGE IS POWER**

Enhance your installation and fabrication skills by enrolling in the most recognized and respected mobile electronics school in our industry. Log onto [www.installerinstitute.com](http://www.installerinstitute.com) or call 800-354-6782 for more information and take steps toward a better tomorrow.



**Metra recommends MECP  
certified technicians**



### Toyota C-HR 2018

Visite [MetraOnline.com](http://MetraOnline.com) para obtener información más detallada sobre el producto y aplicaciones actualizadas específicas para vehículos.

#### CARACTERÍSTICAS DEL KIT

- Provisión de radio ISO DDIN
- Pintura negra de alto brillo

#### COMPONENTES DEL KIT

- A) Soportes del radio • B) Panel de moldura para carcasa de radio • C) (4) tornillos Phillips #6 x 3/8"

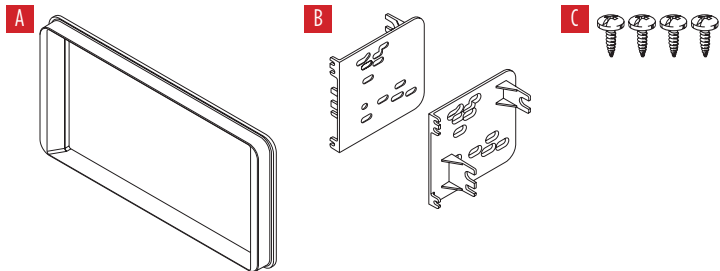

#### INDICE

Desmontaje del tablero .....	2
Ensamble del kit .....	3

#### CABLEADO Y CONEXIONES DE ANTENA

(se venden por separado)

Arnés de cableado: 70-1761

Adaptador de antena: 40-LX10

#### HERRAMIENTAS REQUERIDAS

- Herramienta para quitar paneles
- Destornillador Phillips
- Llave de tubo de 10 mm

**¡Atención!** Deje que el vehículo se asiente con la llave fuera del encendido durante unos minutos antes de quitar la radio de fábrica. Al probar el equipo del mercado de accesorios, asegúrese de que todo el equipo de fábrica esté conectado antes de encender el llave de encendido.

## DESMONTAJE DEL TABLERO

1. Desenganche y quite el panel de moldura que rodea el radio de fábrica que incluye el reloj. (Figura A)
2. Quite (4) pernos de 10 MM que fijan el radio. Después, quítelo. (Figura B)

Continúe con *Ensamble del Kit*

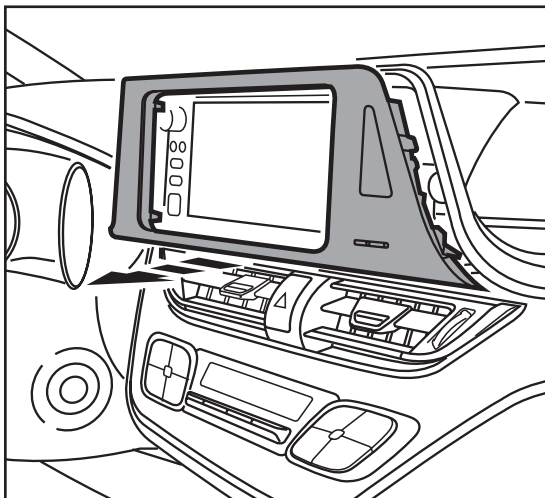

(Figura A)

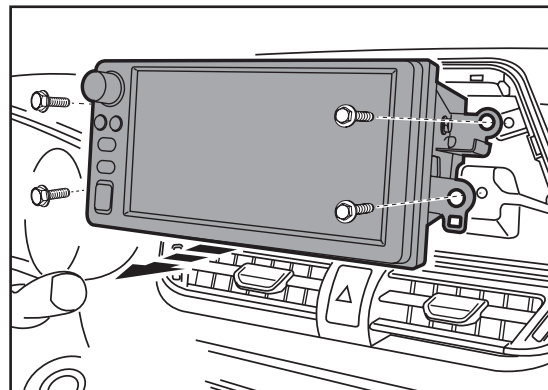

(Figura B)

## ENSAMBLE DEL KIT

1. Fije los **soportes del radio** al **panel de moldura para carcasa de radio** con los (4) tornillos #6 X 3/8" incluidos.
2. Deslice el radio dentro del ensamble y fíjelo con los tornillos incluidos con el radio.
3. Ubique el arnés de cableado de fábrica y el conector de antena en el tablero y realice todas las conexiones necesarias al radio. Metra recomienda el uso de adaptadores de acoplamiento adecuados de Metra o de AXXESS. Pruebe el radio para asegurarse de que funciona bien.
4. Monte el ensamble del radio nuevo al tablero.
5. Vuelva a armar el tablero en el orden inverso de como lo desarmó.

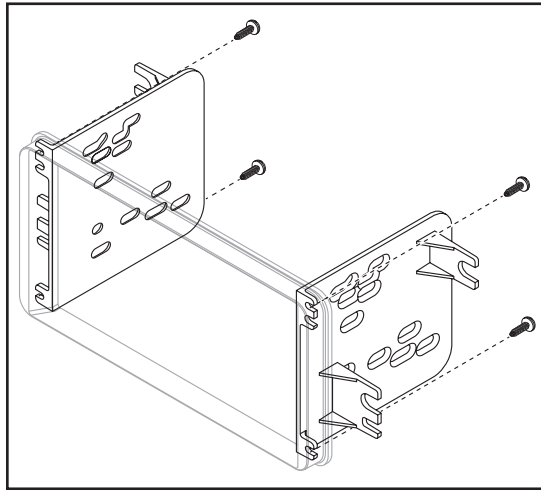

(Figura A)

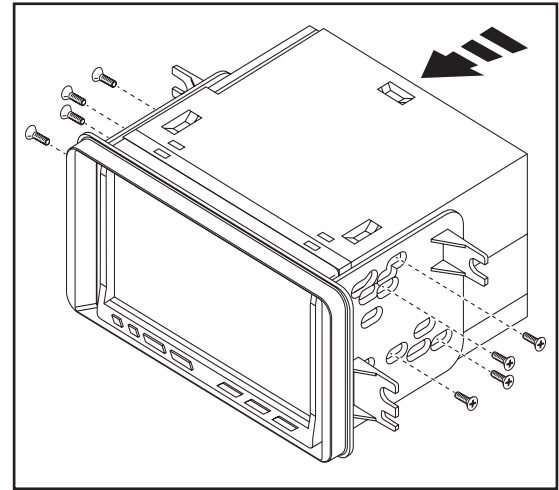

(Figura B)



**95-8265HG**  
INSTRUCCIONES DE INSTALACIÓN



¿Tienes dificultades? Estamos aquí para ayudar.



Póngase en contacto con nuestra  
línea de soporte técnico en:  
**386-257-1187**



O por correo electrónico a:  
[techsupport@metra-autosound.com](mailto:techsupport@metra-autosound.com)

#### **Horas de soporte técnico (hora estándar del este)**

Monday - Friday: 9:00 AM - 7:00 PM

Saturday: 10:00 AM - 7:00 PM

Sunday: 10:00 AM - 4:00 PM



#### **KNOWLEDGE IS POWER**

Enhance your installation and fabrication skills by enrolling in the most recognized and respected mobile electronics school in our industry. Log onto [www.installerinstitute.com](http://www.installerinstitute.com) or call 800-354-6782 for more information and take steps toward a better tomorrow.



**Metra recomienda MECP  
técnicos certificados**