



## Kia Sportage (without NAV, with Display radio†) 2017-up\*

\*Visit [MetraOnline.com](http://MetraOnline.com) for more detailed information about the product and up-to-date vehicle specific applications

† Display radio is an Android Auto/Apple CarPlay radio

### KIT FEATURES

- ISO DIN radio provision with pocket
- ISO DDIN radio provision
- Includes an ASWC-1, AX-CAM6V, antenna adapter, and wiring harness for a complete installation

### KIT COMPONENTS

- A) Radio trim panel • B) Radio brackets • C) Pocket • D) Climate display • E) (2) #8 x 3/8" Phillips screws • F) Wiring harness (not shown)

A

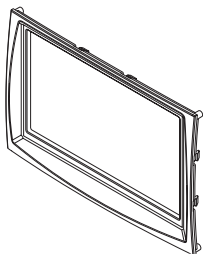

B

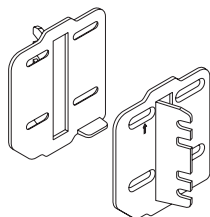

C

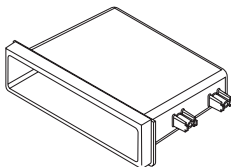

D

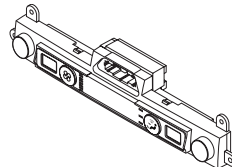

E



### TABLE OF CONTENTS

Dash Disassembly .....	2-3
Kit Preparation .....	4-6
Kit Assembly .....	7
Wiring Instructions .....	8-15

### WIRING & ANTENNA CONNECTIONS

- Wiring Harness: Included with kit
- Antenna Adapter: Included with kit

### TOOLS REQUIRED

- Panel removal tool • Phillips screwdriver
- Pick tool

**Attention!** Let the vehicle sit with the key out of the ignition for a few minutes before removing the factory radio. When testing the aftermarket equipment, ensure that all factory equipment is connected before cycling the key to ignition.

## DASH DISASSEMBLY

1. Unclip and slide the top of the center console back slightly. (Figure A)
2. Unclip and remove the panel on the end of the passenger side of the dash, then remove (1) Phillips screw exposed. (Figure B)

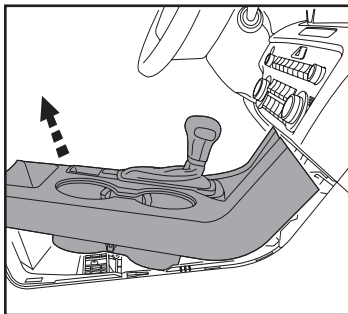

(Figure A)

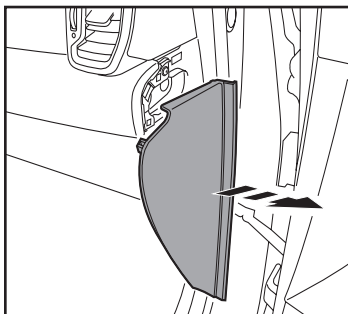

(Figure B)

3. Unclip the panel above the glove box. Unplug the passenger airbag light, then remove the panel. (Figure C)
4. Remove (2) Phillips screws securing the radio display and a/c vent panel, then unclip and remove the panel. (Figure D)

*Continued on the next page*

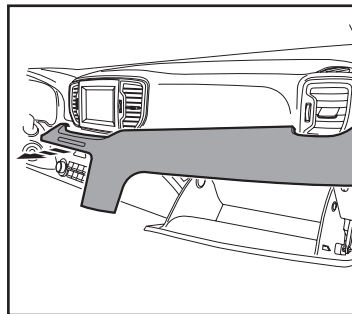

(Figure C)

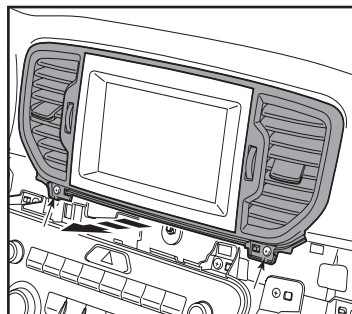

(Figure D)

## DASH DISASSEMBLY (CONT.)

- Remove (4) Phillips screws securing the radio. Slide the radio out, then unplug and remove the radio. (Figure E)
- Remove (3) Phillips screw securing the climate control panel. (Figure F)

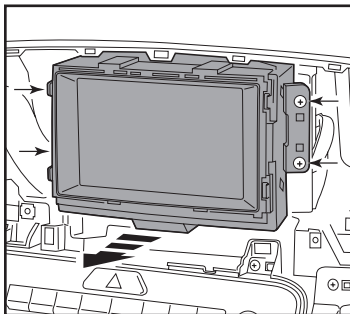

(Figure E)

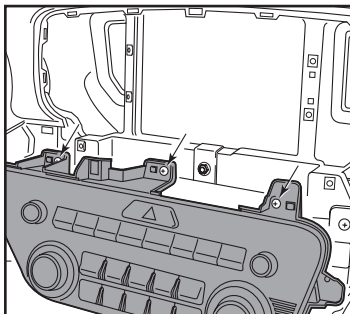

(Figure F)

- Remove (1) Phillips screw securing the lower right side drivers knee bolster. Unsnap the bolster just enough to access the (1) Phillips screw securing the climate control panel, then remove the screw. (Figure G)
- Unclip the climate/radio control panel from the dash, unplug the connectors, then remove the panel. (Figure H)

*Continue to Kit Preparation*

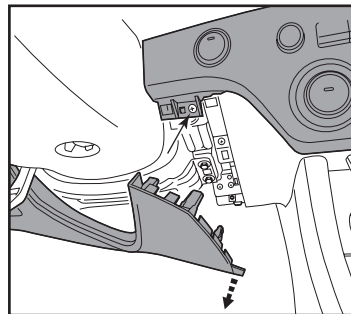

(Figure G)

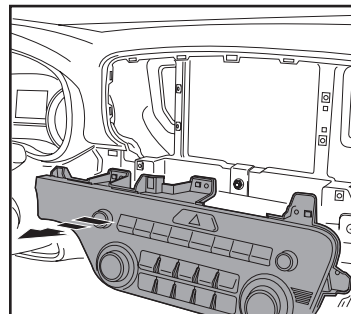

(Figure H)

## KIT PREPARATION

### Radio Trim Panel Installation

#### From the factory radio trim panel:

1. Remove (4) Phillips screws securing the inner trim panel, then remove the panel. (Figure A)

#### To the factory radio trim panel:

2. Secure the 99-7389B radio trim panel to the panel using with the factory screws. (Figure B)

*Continued on the next page*

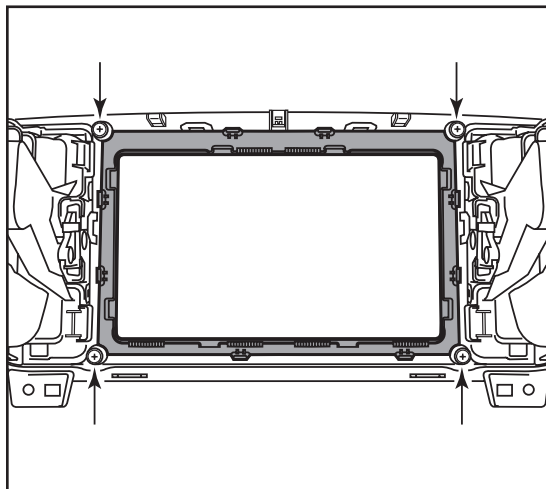

(Figure A)

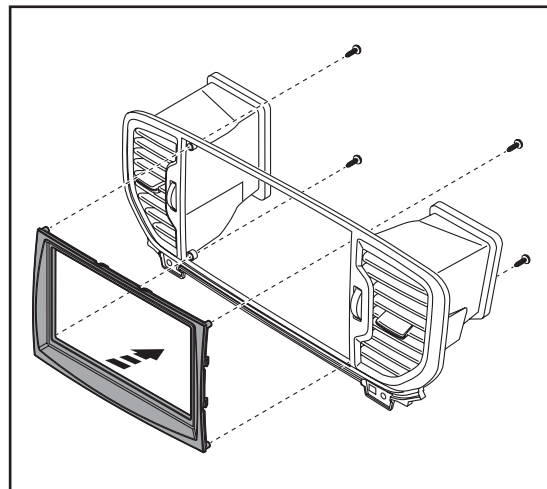

(Figure B)

## KIT PREPARATION (CONT.)

### Climate Display Installation

1. Remove (4) Phillips screws securing the radio/hazard assembly to the climate/radio control panel, then unclip and remove the assembly. (Figure C, heavier arrows)
2. Remove (9) Phillips screws securing the back cover to the radio/hazard assembly, then remove the cover. (Figure C)
3. Using a pick tool, gently release (4) clips holding the hazard switch to the assembly, then remove the switch. (Figure D)

*Continued on the next page*

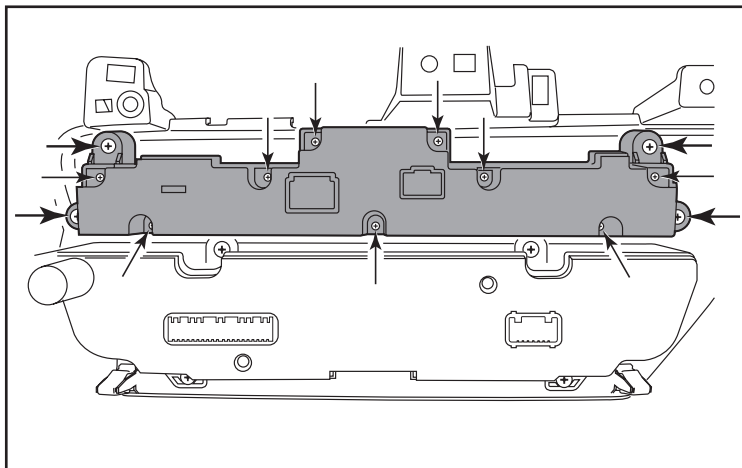

(Figure C)

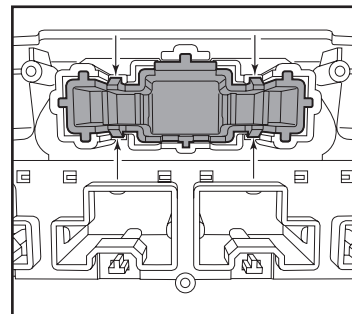

(Figure D)

## KIT PREPARATION (CONT.)

4. Clip the hazard switch into the *climate display*. (Figure E)
5. Secure the climate-display/hazard-switch assembly to the climate control panel using the factory screws. (Figure F)

*Continue to Kit Assembly*

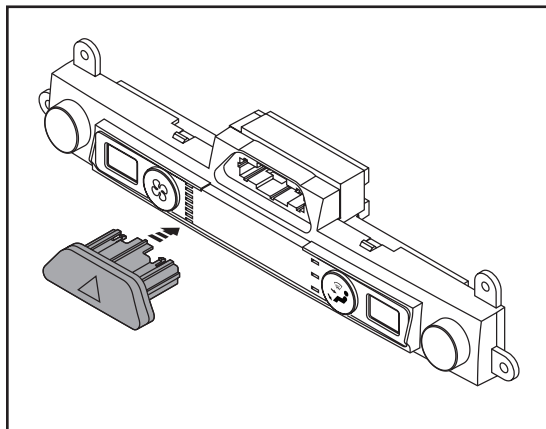

(Figure E)

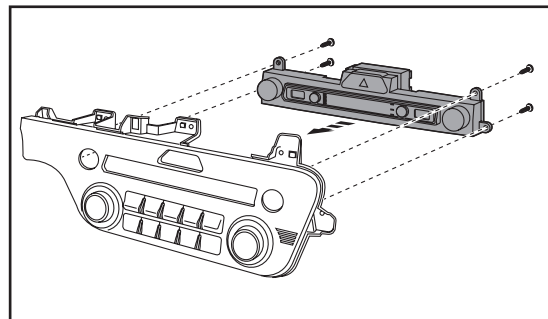

(Figure F)

## KIT ASSEMBLY

### ISO DIN radio provision with pocket

1. Secure the *radio brackets* to the *pocket* using the (2) #8 x 3/8" Phillips screws provided. (Figure A)
2. Remove the metal DIN sleeve and trim ring from the aftermarket radio.
3. Slide the radio into the bracket/pocket assembly, then secure it to the assembly using the screws supplied with the radio. (Figure B)

*Continue to Wiring Instructions*

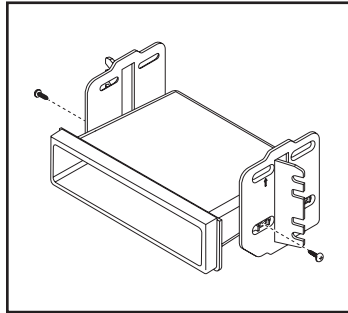

(Figure A)

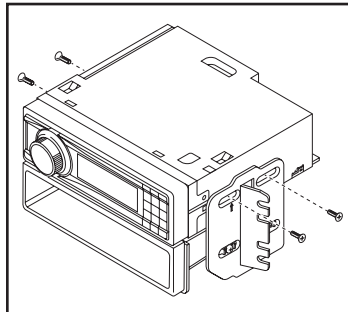

(Figure B)

### ISO DDIN radio provision

1. Secure the *radio brackets* to the radio using the screws supplied with the radio. (Figure A)

*Continue to Wiring Instructions*

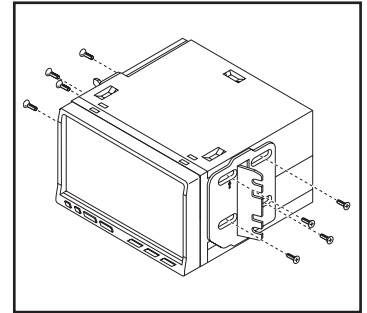

(Figure A)

# WIRING INSTRUCTIONS

## FEATURES

---

- Retains audio controls on the steering wheel via an ASWC-1
- Provides NAV outputs (speed sense)
- Retains the factory AUX-IN jack
- Retains the factory backup camera
- Includes an AX-CAM6V 12-to-6V step-down for the factory camera
- Retains balance and fade

## COMPONENTS

---

- Female 3.5mm connector with stripped leads
- ASWC-1
- AX-CAM6V
- Wiring harness

## TABLE OF CONTENTS

---

Connections .....	9-10
Installation .....	10
Final Assembly .....	11
Programming the ASWC-1 and climate display .....	11
(ASWC-1) Steering wheel control settings .....	12-15
- L.E.D. feedback	
- Changing radio type	
- Remapping the steering wheel control buttons	
- Dual assignment instructions (long button press)	

## TOOLS REQUIRED

---

- Crimping tool and connectors, or solder gun, solder, and heat shrink
- Tape • Wire cutter • Zip ties



## CONNECTIONS

### From the wiring harness included with the kit to the aftermarket radio:

- Connect the (2) **Black** wires, the **Black** wire labeled “CAMERA GROUND”, and also the **Black** wire from the AX-CAM6V, to the ground wire.
- Connect the **Yellow** wire to the battery wire.
- Connect the **Red** wire to the accessory wire.
- Connect the **Red** wire labeled “CAMERA POWER 6V” to the **Blue/Red** wire from the AX-CAM6V.
- Connect the **Blue** wire to the power antenna wire.
- If the aftermarket radio has an illumination wire, connect the **Orange** wire to it.
- Connect the **Gray** wire to the right front positive speaker output.
- Connect the **Gray/Black** wire to the right front negative speaker output.
- Connect the **White** wire to the left front positive speaker output.
- Connect the **White/Black** wire to the left front negative speaker output.
- Connect the **Green** wire to the left rear positive speaker output.
- Connect the **Green/Black** wire to the left rear negative speaker output.
- Connect the **Purple** wire to the right rear positive speaker output.
- Connect the **Purple/Black** wire to the right rear negative output.

*The following (1) wire is only for a multimedia/navigation radio that requires this wire.*

- Connect the **Blue/Pink** wire to the VSS/speed sense wire.
- Connect the **Blue/White** wire from the AX-CAM6V to a wire that has power while the vehicle is in reverse. This wire will have to be located in the vehicle.
- If retaining the factory AUX-In jack, connect the **Red** and **White** RCA jacks to the audio AUX-IN jacks from the aftermarket radio.
- Connect the **Yellow** RCA jack to the backup camera input.

*Continued on the next page*

### 3.5mm jack steering wheel control retention:

The 3.5mm jack is to be used to retain audio controls on the steering wheel.

- For the radios listed below, connect the *female 3.5mm connector with stripped leads*, to the male 3.5mm SWC jack from the wiring harness included with the kit. Any remaining wires tape off and disregard:
  - **Eclipse:** Connect the steering wheel control wire, normally **Brown**, to the **Brown/White** wire of the connector. Then connect the remaining steering wheel control wire, normally **Brown/White**, to the **Brown** wire of the connector.
  - **Metra OE:** Connect the steering wheel control Key 1 wire (**Gray**) to the **Brown** wire.
  - **Kenwood or select JVC with a steering wheel control wire:** Connect the **Blue/Yellow** wire to the **Brown** wire.  
**Note:** If your **Kenwood** radio auto detects as a **JVC**, manually set the radio type to **Kenwood**. See the instructions under changing radio type.
  - **XITE:** Connect the steering wheel control SWC-2 wire from the radio to the **Brown** wire.
  - **Parrot Asteroid Smart or Tablet:** Connect the 3.5mm jack into the AX-SWC-PARROT (sold separately), and then connect the 4-pin connector from the AX-SWC-PARROT into the radio.  
**Note:** The radio must be updated to rev. 2.1.4 or higher software.
  - **Universal “2 or 3 wire” radio:** Connect the steering wheel control wire, referred to as Key-A or SWC-1, to the **Brown** wire of the connector. Then connect the remaining steering wheel control wire, referred to as Key-B or SWC-2, to the **Brown/White** wire of the connector. If the radio comes with a third wire for ground, disregard this wire. **Note:** After the interface has been programmed to the vehicle, refer to the manual provided with the radio for assigning the SWC buttons. Contact the radio manufacturer for more information.
- **For all other radios:** Connect the 3.5mm jack from the wiring harness included with the kit into the jack on the aftermarket radio designated for an external steering wheel control interface. Please refer to the aftermarket radios manual if in doubt as to where the 3.5mm jack goes to.

### With the key in the off position:

1. Connect the wiring harness included with the kit to the climate-display/hazard-switch assembly, and then to the wiring harness in the vehicle.
2. Locate the factory antenna connector in the dash and complete all necessary connections to the radio. Use the antenna adapter provided to adapt the factory antenna connector to the aftermarket radio.
3. Connect the wiring harness included with the kit to the ASWC-1.

**Attention!** If retaining steering wheel controls, ensure that the SWC jack/wire is connected to the radio before proceeding. If this step is skipped, the ASWC-1 will need to be reset for the steering wheel controls to function.

## PROGRAMMING THE ASWC-1 AND CLIMATE DISPLAY

### Programming the ASWC-1:

1. Press and hold the “Volume-Up” button on the steering wheel, then turn the ignition on. The L.E.D. will start flashing rapidly, which means the ASWC-1 is looking for the vehicle and the radio.  
**Note:** If the L.E.D. didn’t start flashing rapidly, press the reset button for 3 seconds, while still holding the “Volume-Up” button.
2. After a few seconds the L.E.D. should stop flashing rapidly, then go out for approximately 2 seconds.
3. After approximately 2 seconds there will be a series of 7 **Green** flashes, some short, and some long. The long flashes represent the wires that are connected to the ASWC-1.  
**Tip:** Knowing this will help to troubleshoot, if need be.
4. The L.E.D. will pause for another 2 seconds, then flash **Red** up to 18 times depending on which radio is connected to the ASWC-1. Refer to the L.E.D. feedback section for information.
5. This is the end of the auto detection stage. If the ASWC-1 detected the vehicle and the radio successfully, the L.E.D. will light up solid. Release from holding the “Volume-Up” button.
6. Test the steering wheel controls for proper operation. Refer to “(ASWC-1) Steering wheel control settings” for customizing the buttons, if so desired.

### Programming the climate display:

7. Turn the parking lights on.
8. Turn the vehicles light dimmer all the way down, then all the way up.
9. Turn the lights off.
10. Test all functions of the installation for proper operation, before reassembling the dash.

## FINAL ASSEMBLY

1. Secure the climate control assembly to the dash in reverse order of disassembly using the factory screws.
2. Secure the radio assembly to the dash using the factory screws.
3. Reassemble the dash in reverse order of disassembly to complete the installation.

## ASWC-1 STEERING WHEEL CONTROL SETTINGS

### L.E.D. feedback

The (18) **Red** L.E.D. flashes represent what brand radio the ASWC-1 believes it is connected to. Each flash represents a different radio Manufacturer. For example, if you are installing a JVC radio, the ASWC-1 will flash **Red** (5) times, and then stop. Following is a legend that dictates which radio Manufacturer corresponds to which flash.

### L.E.D. Feedback Legend

Flash Count	Radio	Flash Count	Radio
1	Eclipse (type 1) †	10	Clarion (type 2) †
2	Kenwood ‡	11	Metra OE
3	Clarion (type 1) †	12	Eclipse (type 2) †
4	Sony / Dual	13	LG
5	JVC	14	Parrot **
6	Pioneer / Jensen	15	XITE
7	Alpine *	16	Phillips
8	Visteon	17	TBA
9	Valor	18	JBL

**\* Note:** If the Axxess interface flashes Red (7) times, and you do not have an Alpine radio connected to it, that means the Axxess interface does not detect a radio connected to it. Verify that the 3.5mm jack is connected to the correct steering wheel jack/wire in the radio.

**\*\* Note:** The AX-SWC-PARROT is required (sold separately). Also, the Parrot radio must be updated to rev. 2.1.4 or higher through [www.parrot.com](http://www.parrot.com).

**† Note:** If you have a Clarion radio and the steering wheel controls do not work, change the radio type to the other Clarion radio type; same for Eclipse. The following section explains how to do this.

**‡ Note:** If you have a Kenwood radio and the L.E.D. feedback comes back showing as a JVC radio, change the radio type to Kenwood. The following section explains how to do this.

**Attention:** The Axxess Updater App can also be used to program the following (3) sub-sections as well, pending that the Axxess interface has been programmed.

*Continued on the next page*

## ASWC-1 STEERING WHEEL CONTROL SETTINGS (CONT.)

### Changing radio type

If the L.E.D. flashes do not match the radio you have connected, you must manually program the Axxess interface to tell it what radio it is connected to.

1. After (3) seconds of turning the key on, press and hold the “Volume-Down” button on the steering wheel until the L.E.D. in the Axxess interface goes solid.
2. Release the “Volume-Down” button; the L.E.D. will go out indicating the Axxess interface is in “Changing Radio Type” mode.
3. Refer to the **Radio Legend** to know which radio number you would like to have programmed.
4. Press and hold the “Volume-Up” button until the L.E.D. goes solid, and then release. Repeat this step for the desired radio number you have selected.
5. Once the desired radio number has been selected, press and hold the “Volume-Down” button on the steering wheel until the L.E.D. goes solid. The L.E.D. will remain on for about (3) seconds while it stores the new radio information.
6. Once the L.E.D. goes out, the “Changing Radio Type” mode will then end. You can now test the steering control wheel controls.

**Note:** If at any time the user fails to press any button for a period longer than (10) seconds, this process will abort.

*Continued on the next page*

### Radio Legend

Radio Number	Radio	Radio Number	Radio
1	Eclipse (type 1)	10	Clarion (type 2)
2	Kenwood	11	Metra OE
3	Clarion (type 1)	12	Eclipse (type 2)
4	Sony / Dual	13	LG
5	JVC	14	Parrot
6	Pioneer / Jensen	15	XITE
7	Alpine	16	Philips
8	Visteon	17	TBA
9	Valor	18	JBL

## ASWC-1 STEERING WHEEL CONTROL SETTINGS (CONT.)

### Remapping the steering wheel control buttons

Once the ASWC-1 has been programmed, the button assignment for the steering wheel controls may be reassigned if so desired. For example, if the “Seek-Up” button is preferred to be the “Mute” button instead. Follow the steps below to remap the steering wheel control buttons.

1. Ensure the Axxess interface is visible so you can see the L.E.D. flashes to confirm button recognition.  
**Tip:** Turning the radio off is recommended.
2. Within the first twenty seconds of turning the ignition on, press and hold the “Volume-Up” button on the steering wheel until the L.E.D. goes solid.
3. Release the “Volume-Up” button, the L.E.D. will then go out; The “Volume-Up” button has now been programmed.
4. Follow the list in the **Button Function Legend** to reference the order in which the steering wheel control buttons need to be programmed.  
**Note:** If the next function on the list is not on the steering wheel, press the “Volume-Up” button for (1) second until the L.E.D. comes on to skip that function, and then release the “Volume-Up” button. This will tell the Axxess interface that this function is not available, and it will move on to the next function.
5. To complete the remapping process, press and hold the “Volume-Up” button until the L.E.D. in the Axxess interface goes out.

*Continued on the next page*

### Button Function Legend

Function #	Function	Function #	Function
1	Volume-Up	10	Band
2	Volume-Down	11	Play/Enter
3	Seek-Up/Next	12	PTT (Push to Talk)
4	Seek-Down/Prev	13	On-Hook
5	Source/Mode	14	Off-Hook
6	Mute	15	Fan-Up *
7	Preset-Up	16	Fan-Down *
8	Preset-Down	17	Temp-Up *
9	Power	18	Temp-Down *

\* Not applicable in this application

**Note:** Some radios may not have these commands. Please refer to the manual provided with the radio, or contact the radio manufacturer for specific commands recognized by that particular radio.

## ASWC-1 STEERING WHEEL CONTROL SETTINGS (CONT.)

### Dual assignment instructions (long button press)

The ASWC-1 has the capability to assign (2) functions to a single button, except “Volume-Up” and “Volume-Down”. Follow the steps below to program the button(s) to the desired setting.

**Note:** “Seek-Up” and “Seek-Down” come pre-programmed as “Preset-Up” and “Preset-Down” for a long button press.

1. Turn the key to ignition but do not start the vehicle.
2. Press and hold the desired steering wheel control button for (10) seconds, or until the L.E.D. flashes rapidly. At this point release the button; the L.E.D. will then go solid.
3. Press and release the “Volume-Up” button the number of times corresponding to the new button number selected. Refer to the **Dual Assignment Legend**. The L.E.D. will flash rapidly while the “Volume-Up” button is being pressed, and then go back to a solid L.E.D. once released. Proceed to the next step once the “Volume-Up” button has been pressed the desired number of times.

**Caution:** If more than (10) seconds elapses between pressing the “Volume-Up” button, this procedure will abort, and the L.E.D. will go out.

4. Press the desired button to store it to memory. The L.E.D. will now go out indicating the new information has been stored to memory.

**Note:** These steps must be repeated for each button desired to assign a dual assignment feature to. To reset a button back to its default state, repeat Step 1, then press the “Volume-Down” button. The L.E.D. will go out, and the dual assignment feature for that button will be erased.

### Dual Assignment Legend

Function #	Function	Function #	Function
1	Not allowed	10	Band
2	Not allowed	11	Play/Enter
3	Seek-Up/Next	12	PTT (Push to Talk)
4	Seek-Down/Prev	13	On-Hook
5	Mode/Source	14	Off-Hook
6	ATT/Mute	15	Fan-Up *
7	Preset-Up	16	Fan-Down *
8	Preset-Down	17	Temp-Up *
9	Power	18	Temp-Down *

\* Not applicable in this application



**99-7389B**  
INSTALLATION INSTRUCTIONS



If you are having difficulties with the installation of this product, contact our Tech Support line either by phone at **1-800-253-TECH**, or email at **techsupport@metra-autosound.com**. Before doing so, look over the instruction booklet a second time and ensure that the installation was performed exactly as the instruction booklet is stated. Have the vehicle apart and ready to perform troubleshooting steps before contacting Metra/Axxess Tech Support.



**KNOWLEDGE IS POWER**

Enhance your installation and fabrication skills by enrolling in the most recognized and respected mobile electronics school in our industry. Log onto [www.installerinstitute.com](http://www.installerinstitute.com) or call 800-354-6782 for more information and take steps toward a better tomorrow.



**Metra recommends MECP certified technicians**