



Kia Rio/Rio 5-Door 2018-up*

*Visit MetraOnline.com for up-to-date vehicle specific applications.

KIT FEATURES

- ISO DIN radio provision with pocket
- Painted matte black

KIT COMPONENTS

- A) Radio trim panel • B) Radio brackets • C) Pocket • D) (8) #8 x 3/8" Phillips screws

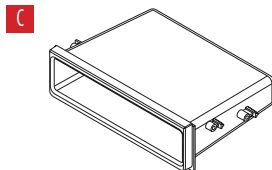
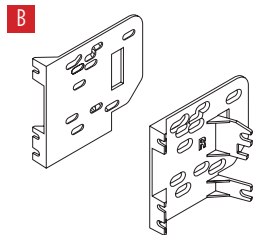
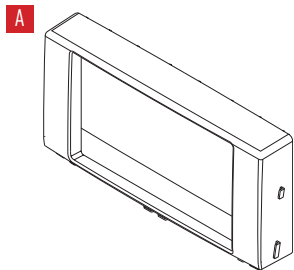

TABLE OF CONTENTS

Dash Disassembly	2
Kit Preparation	2
Kit Assembly	3

WIRING & ANTENNA CONNECTIONS (sold separately)

Wiring Harness: Please visit metraonline.com for wiring harness options

Antenna Adapter: 40-K11

Steering Wheel Control Interface: ASWC-1

TOOLS REQUIRED

- Panel removal tool • Phillips screwdriver
- Cutting tool

CAUTION! All accessories, switches, climate controls panels, and especially air bag indicator lights must be connected before cycling the ignition. Also, do not remove the factory radio with the key in the on position, or while the vehicle is running.

DASH DISASSEMBLY

1. Unclip and remove the top half of the steering column shroud and gauge cluster trim panel. These panels are connected together by a piece of material and will come out as one piece. (Figure A)
2. Unclip and remove the a/c vent panel surrounding the radio. (Figure B)
3. Remove (4) screws securing the radio. Slide the radio out, then unplug and remove the radio.

Continue to Kit Preparation

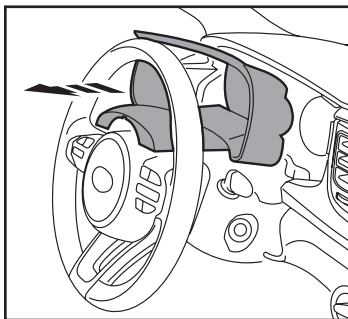

(Figure A)

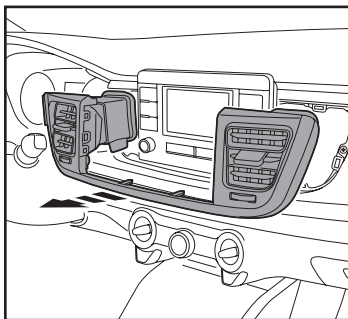

(Figure B)

KIT PREPARATION

1. Cut the shaded area in the sub-dash to allow room for the aftermarket radio. (Figure A)

Continue to Kit Assembly

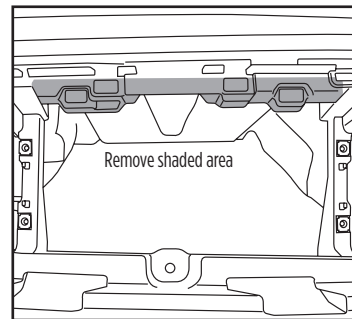

(Figure A)

KIT ASSEMBLY

1. Secure the *radio brackets* to the *radio trim panel* using the (4) #8 x 3/8" Phillips screws provided. (Figure A)
2. Slide the *pocket* into the bracket/panel assembly, then secure it using the (4) #8 x 3/8" Phillips screws provided. (Figure B)
3. Remove the metal DIN sleeve and trim ring from the aftermarket radio.
4. Slide the radio into the bracket/panel/pocket assembly, then secure it using the screws supplied with the radio. (Figure C)

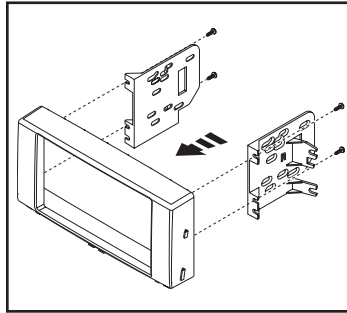

(Figure A)

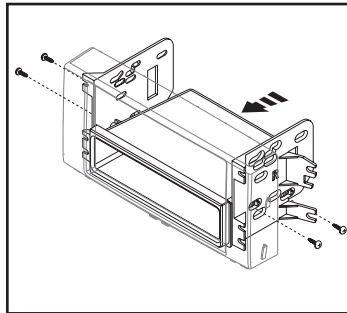

(Figure B)

5. Locate the factory wiring harness and antenna connector in the dash and complete all necessary connections to the radio. Metra recommends using the proper mating adapter from Metra and/or Axxess. Test the radio for proper operation.
6. Secure the radio assembly to the dash using the factory screws.
7. Reassemble the dash in reverse order of disassembly to complete the installation.

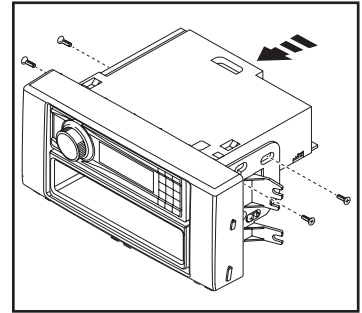

(Figure C)



99-7391B
INSTALLATION INSTRUCTIONS



IMPORTANT

If you are having difficulties with the installation of this product, please call our Tech Support line at 1-800-253-TECH. Before doing so, look over the instructions a second time, and make sure the installation was performed exactly as the instructions are stated. Please have the vehicle apart and ready to perform troubleshooting steps before calling.



KNOWLEDGE IS POWER

Enhance your installation and fabrication skills by enrolling in the most recognized and respected mobile electronics school in our industry. Log onto www.installerinstitute.com or call 800-354-6782 for more information and take steps toward a better tomorrow.



**Metra recommends MECP
certified technicians**