



INSTALLATION INSTRUCTIONS FOR PART 99-7405

APPLICATIONS

Nissan Titan 2004-up *(base model only)* 99-7405

KIT FEATURES

- DIN radio provision with pocket
- ISO DIN radio provision with pocket



KIT COMPONENTS

- A) Radio housing
- B) ISO Brackets
- C) ISO Trim plate

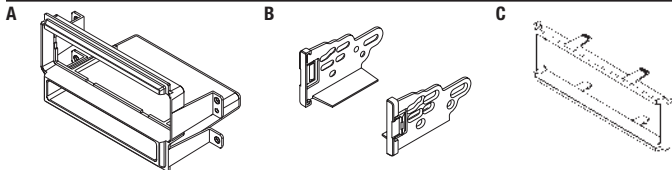

WIRING & ANTENNA CONNECTIONS *(sold separately)*

Wiring Harness: • 70-7550 - Nissan 1995-up • 70-7551 - Nissan 1995-up • 70-7552 - Nissan 2007-up

Antenna Adapter: • Not required

TOOLS REQUIRED

- Panel removal tool
- Socket wrench

Table of Contents

Dash Disassembly

- Nissan Titan 2004-up 2

Kit Assembly

- DIN radio provision with pocket..... 3
- ISO DIN radio provision with pocket..... 3

CAUTION: Metra recommends disconnecting the negative battery terminal before beginning any installation. All accessories, switches, and especially air bag indicator lights must be plugged in before reconnecting the battery or cycling the ignition.

NOTE: Refer to the instructions included with the aftermarket radio.

Nissan Titan 2004-up

1. Unclip and remove entire panel surrounding radio and climate controls. (Figure A)
2. Remove (4) Phillips screws to remove radio. (Figure B)

Continue to kit assembly

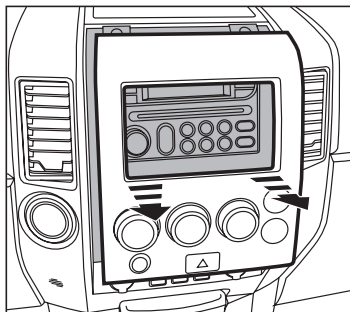

(Figure A)

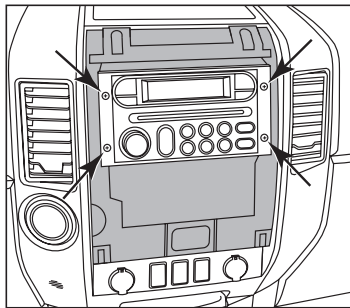

(Figure B)

DIN radio provision with pocket

1. Locate the factory wiring harness in the dash. Metra recommends using the proper mating adapter from Metra or AXCESS. Re-connect the negative battery terminal and test the radio for proper operation.
2. Slide the DIN cage into the radio housing and secure by bending the metal locking tabs down. (Figure A)
3. Slide the after-market radio into the cage and secure. (Figure B)
4. Reassemble dash in reverse order of disassembly.

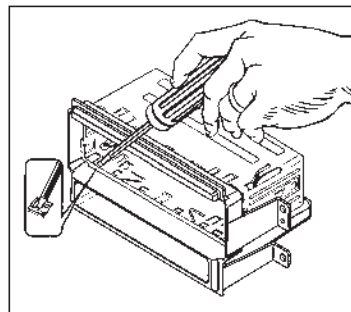

(Figure A)

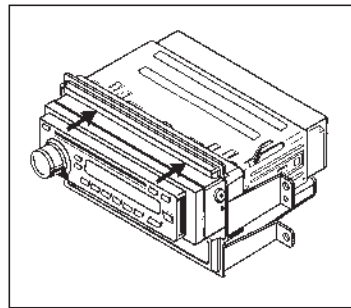

(Figure B)

ISO DIN radio provision with pocket

1. Locate the factory wiring harness in the dash. Metra recommends using the proper mating adapter from Metra or AXXESS. Re-connect the negative battery terminal and test the radio for proper operation.
2. Mount the ISO Brackets to the radio with the screws supplied with the radio. (Figure A)
3. Slide the radio into the radio opening until the side clips engage and then snap the Trim plate into the radio housing. (Figure B)
4. Reassemble dash in reverse order of disassembly.

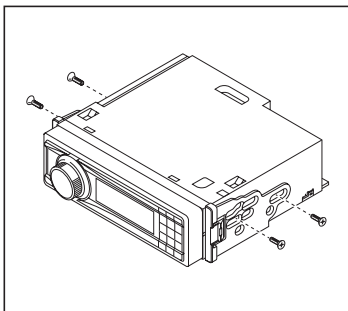

(Figure A)

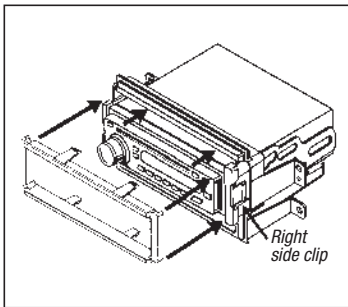

(Figure B)

Notes



INSTALLATION INSTRUCTIONS FOR PART 99-7405



REV. 4/1/2014 INST99-7405



KNOWLEDGE IS POWER

Enhance your installation and fabrication skills by enrolling in the most recognized and respected mobile electronics school in our industry. Log onto www.installerinstitute.com or call 800-354-6782 for more information and take steps toward a better tomorrow.



**Metra recommends MECP
certified technicians**