



Nissan NP300 2017-up*

*Visit MetraOnline.com for up-to-date vehicle specific applications.

KIT FEATURES

- ISO DIN radio provision with pocket
- ISO DDIN radio provision
- Painted matte black

KIT COMPONENTS

- A) Radio trim panel • B) Radio brackets • C) Pocket • D) (4) #8 x 3/8" Phillips screws • E) (10) Panel clips

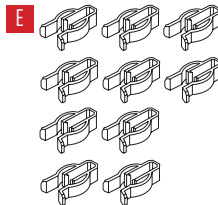
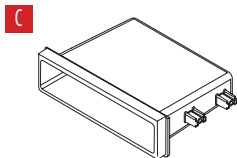
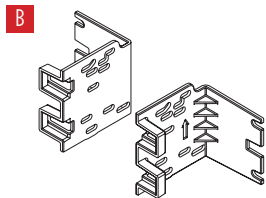
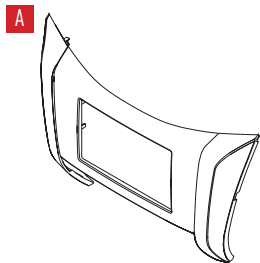

TABLE OF CONTENTS

Dash Disassembly	2
Kit Assembly	3
–ISO DIN radio provision with pocket	3
–ISO DDIN radio provision.....	3

WIRING & ANTENNA CONNECTIONS (sold separately)

Wiring Harness: 70-7552

Antenna Adapter: 40-N112

TOOLS REQUIRED

- Panel removal tool • Phillips screwdriver

CAUTION! All accessories, switches, climate controls panels, and especially air bag indicator lights must be connected before cycling the ignition. Also, do not remove the factory radio with the key in the on position, or while the vehicle is running.

DASH DISASSEMBLY

1. Unclip and remove the left and right side panels from the factory radio (or pocket in radio delete models).
2. Remove (2) Phillips screw securing the climate control trim panel, and then unclip and remove the panel.
3. Remove (4) Phillips screw securing the radio or pocket trim panel, and then unclip and remove the panel.
4. Remove (4) Phillips screws securing the radio or pocket, then unplug and remove the radio or pocket.

Please visit Metraonline.com for Dash Disassembly illustrations.

Continue to Kit Assembly

KIT ASSEMBLY

ISO DIN radio provision with pocket

1. Secure the *pocket* to the *radio brackets* using the (4) #8 x 3/8" Phillips screws provided. (Figure A)
2. Remove the metal DIN sleeve and trim ring from the aftermarket radio.
3. Slide the radio into the bracket/pocket assembly, and then secure it using the screws supplied with the radio. (Figure B)
4. Locate the factory wiring harness and antenna connector in the dash and complete all necessary connections to the radio. Metra recommends using the proper mating adapter from Metra and/or Axxess. Test the radio for proper operation.
5. Secure the radio assembly to the dash using the factory screws.
6. Attach the (10) *panel clips* onto the radio trim panel, then snap the panel over the radio assembly to complete the installation.

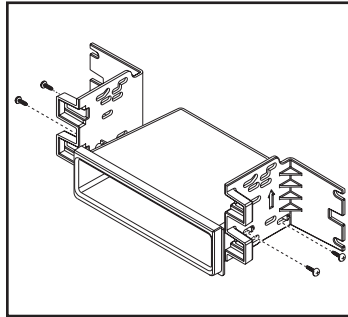

(Figure A)

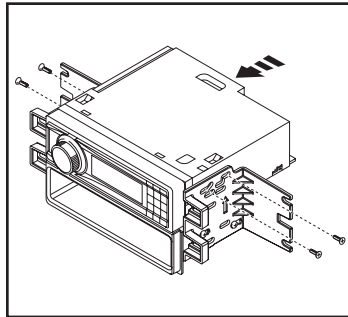

(Figure B)

ISO DDIN radio provision

1. Secure the *radio brackets* to the radio using the screws supplied with the radio. (Figure A)
2. Locate the factory wiring harness and antenna connector in the dash and complete all necessary connections to the radio. Metra recommends using the proper mating adapter from Metra and/or Axxess. Test the radio for proper operation.
3. Secure the radio assembly to the dash using the factory screws.
4. Attach the (10) *panel clips* onto the radio trim panel, then snap the panel over the radio assembly to complete the installation.

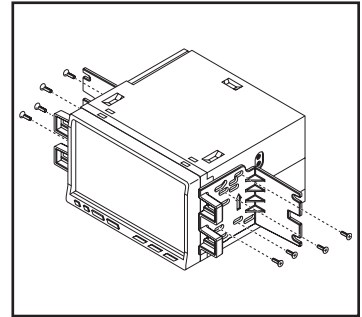

(Figure A)



99-7634B
INSTALLATION INSTRUCTIONS



IMPORTANT

If you are having difficulties with the installation of this product, please call our Tech Support line at 1-800-253-TECH. Before doing so, look over the instructions a second time, and make sure the installation was performed exactly as the instructions are stated. Please have the vehicle apart and ready to perform troubleshooting steps before calling.



KNOWLEDGE IS POWER

Enhance your installation and fabrication skills by enrolling in the most recognized and respected mobile electronics school in our industry. Log onto www.installerinstitute.com or call 800-354-6782 for more information and take steps toward a better tomorrow.



**Metra recommends MECP
certified technicians**