



INSTALLATION INSTRUCTIONS FOR PART 99-8205

APPLICATIONS Toyota Matrix 2003-2008 Pontiac Vibe 2003-2008

99-8205

KIT FEATURES

- DIN head unit provision
- ISO DIN head unit provision
- DDIN head unit provision
- Excluding 2005-2008 Matrix
- Stacked ISO DIN head unit provision
- Excluding 2005-2008 Matrix



KIT COMPONENTS

- A) DDIN Faceplate (excluding 2005-2008 matrix) • B) ISO DIN Faceplate (excluding 2005-2008 matrix)
 • C) ISO DIN Faceplate 2005-2008 Matrix D) Pocket • E) Mounting Brackets • F) ISO Trim Plate • G) ISO Brackets
 • H) ISO Spacers • I) Rear Support • J) (4) #6x1/4" Phillip Screws • K) (4) #8x3/8" Phillip Screws

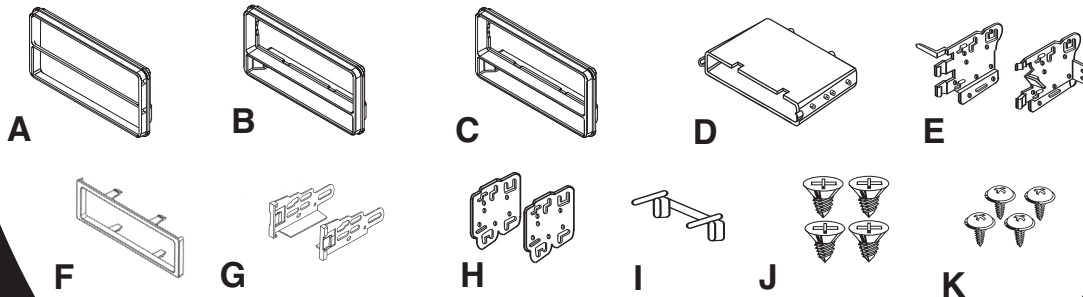

TOOLS REQUIRED:

- Cutting Tool • Phillips Screwdriver • Socket Wrench

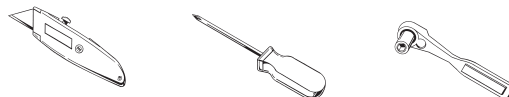

1-800-221-0932



www.metraonline.com



TABLE OF CONTENTS

***Dash Disassembly*1,2**

***Kit Assembly* 3, 4, 5, 6, 7,8**

***Final Assembly* 9**



KNOWLEDGE IS POWER

Enhance your installation and fabrication skills by enrolling in the most recognized and respected mobile electronics school in our industry. Log onto www.installerinstitute.com or call 800-354-6782 for more information and take steps toward a better tomorrow.

TOYOTA MATRIX 2003-2008

PONTIAC VIBE 2003-2008

- 1 Disconnect the negative battery terminal to prevent an accidental short circuit.

- 2 Unclip the bottom edge of the radio trim panel then lift up and out to remove. (Figure A)

- 3 Remove (4) 10 MM bolts securing the factory radio. (Figure B)

A

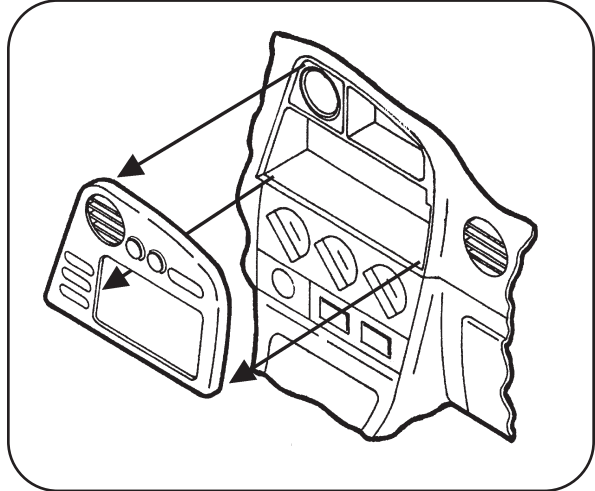

B

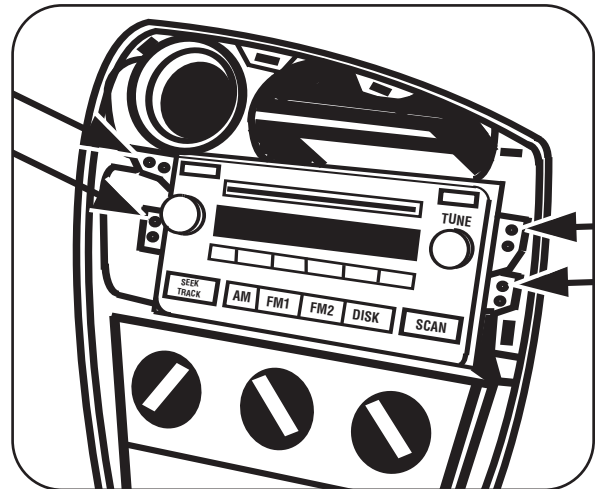

DIN HEAD UNIT PROVISION

- 1 Choose the correct faceplate for your application. The 2005-2008 Matrix faceplate is smaller than the other supplied faceplate.
- 2 Attach the pocket to the back of the ISO/DIN Faceplate (by holding the faceplate upside down and inserting the right edge of the pocket into place then pushing the rest of the pocket onto the lip) and mount with (2) #8X3/8" Phillips screws. (Figure A)

A

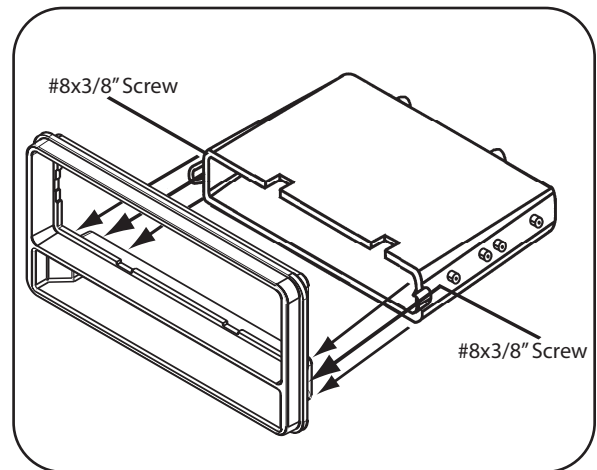

NOTE: For the 2005-2008 Matrix, break away the shaded clips along the scored lines. (Figure B)

B

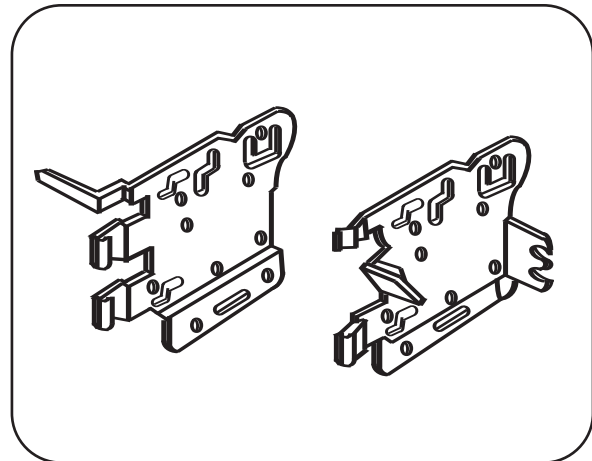

- 3 Secure the mounting brackets to the pocket with (4) #6X1/4" Phillips screws. (Figure C)

C

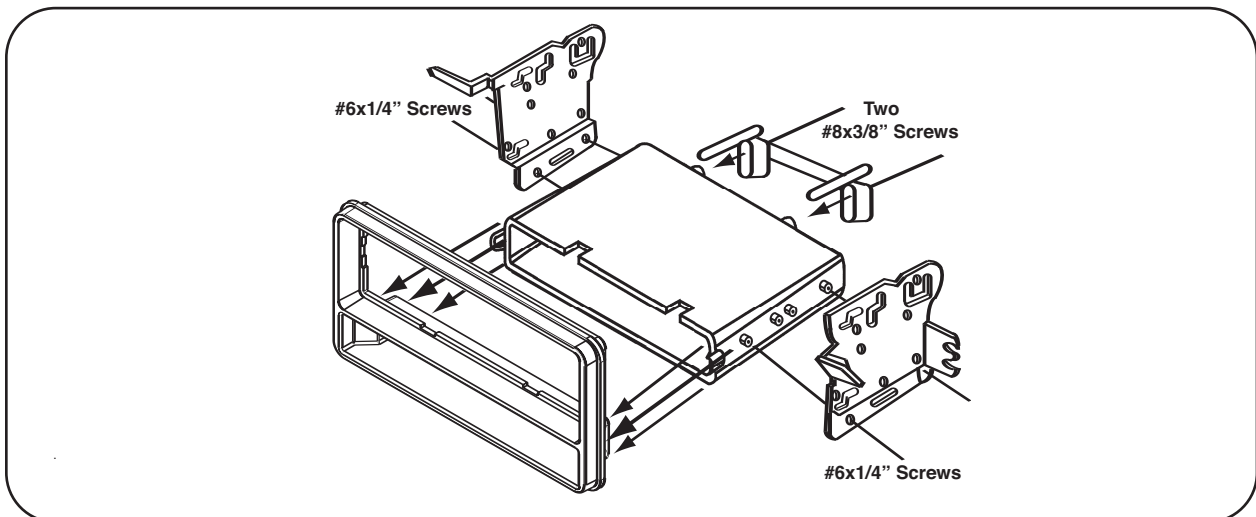

DIN HEAD UNIT PROVISION

- 4 Mount the rear support to the back of the pocket with (2) #8X3/8" Phillips screws. (Figure D)
- 5 Slide the DIN cage into the Radio Housing and secure by bending the metal locking tabs down. (Figure E)
- 6 Slide the aftermarket head unit into the cage and secure. (Figure F)

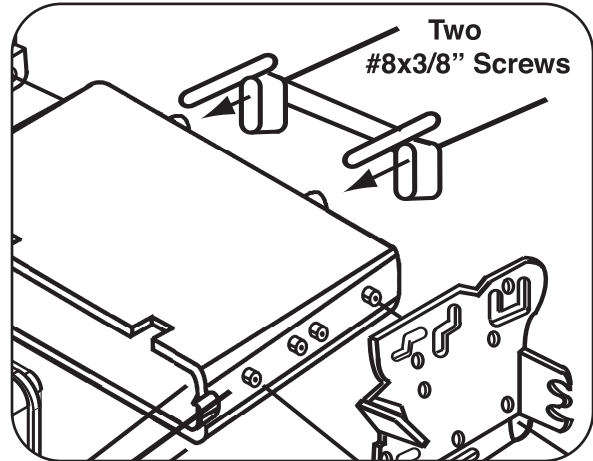
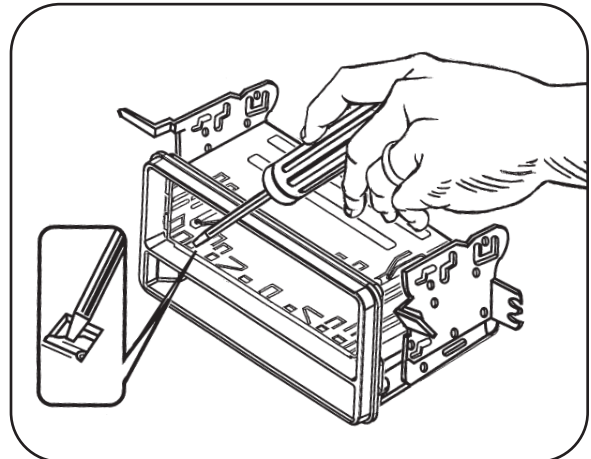
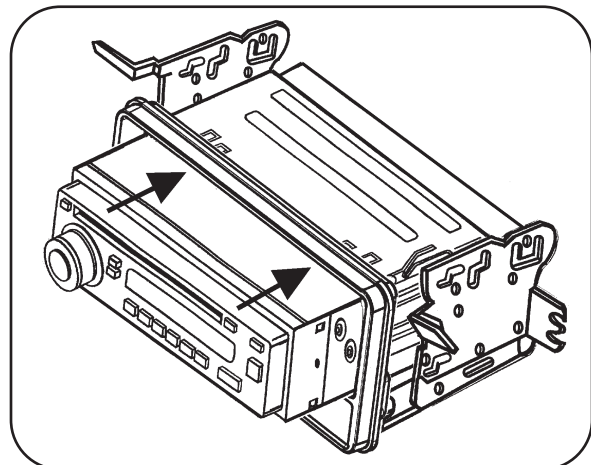
D**E****F**

ISO DIN HEAD UNIT PROVISION

- 1 Choose the correct faceplate for your application. The 2005-2008 Matrix faceplate is smaller than the other supplied faceplate.
- 2 Attach the the pocket to the back of the ISO/DIN Faceplate (by holding the faceplate upside down and inserting the right edge of the pocket into place then pushing the rest of the pocket onto the lip) and mount with (2) #8X3/8" Phillips screws. (Figure A)

A

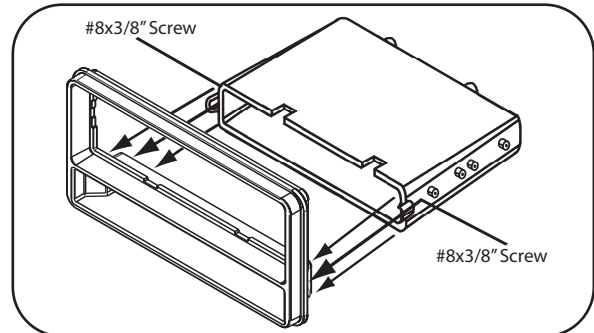

NOTE: For the 2005-2008 Matrix, break away the shaded clips along the scored lines. (Figure B)

B

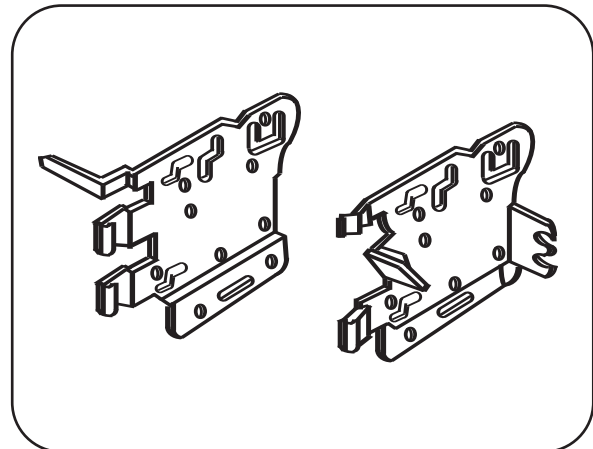

- 3 Secure the mounting brackets to the pocket with (4) #6X1/4" Phillips screws. (Figure C)

C

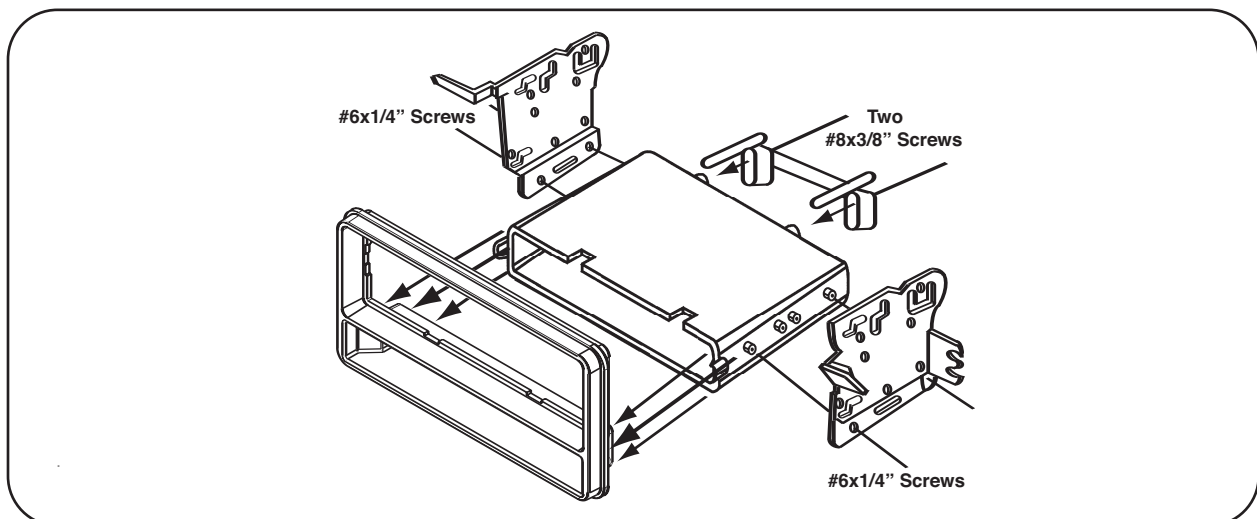

ISO DIN HEAD UNIT PROVISION

- 4** Mount the rear support to the back of the pocket with (2) #8x3/8" Phillips screws. **(Figure D)**
- 5** Mount the ISO Brackets to the head unit with the screws supplied with the unit. **(Figure E)**
- 6** Slide the the head unit into the radio opening until the side clips engage. **(Figure F)**
- 7** Snap the Trim plate into the Radio Housing. **(Figure F)**

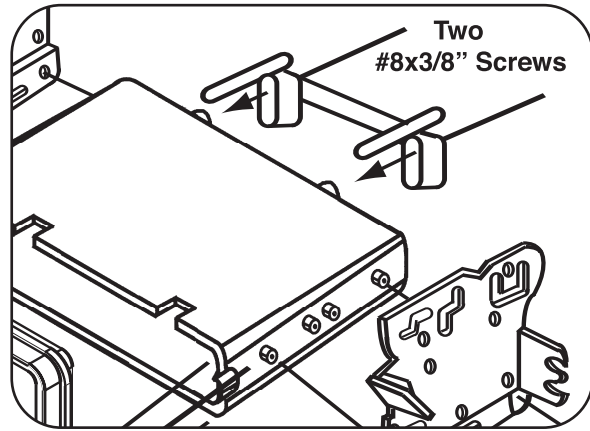
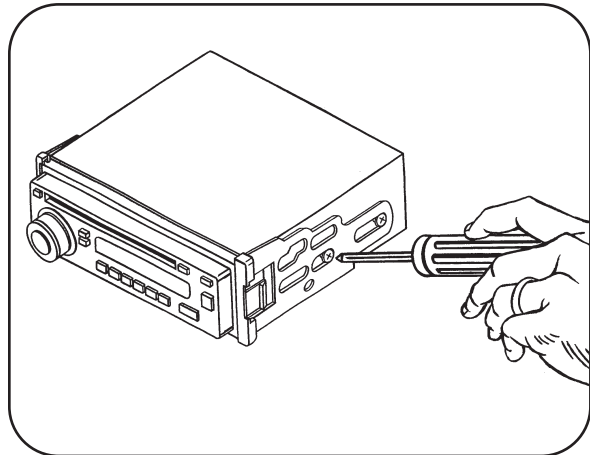
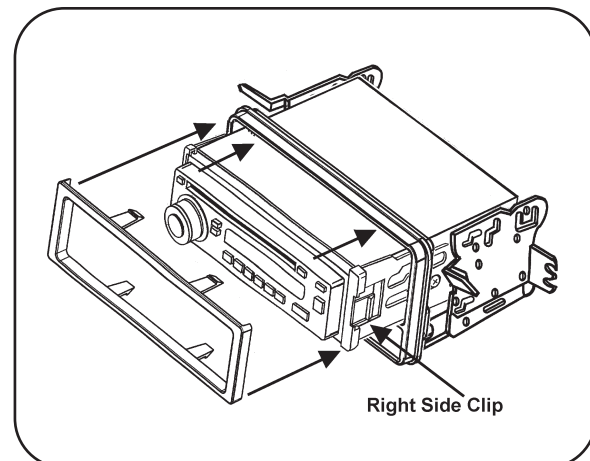
D

E

F

DOUBLE DIN HEAD UNIT PROVISION

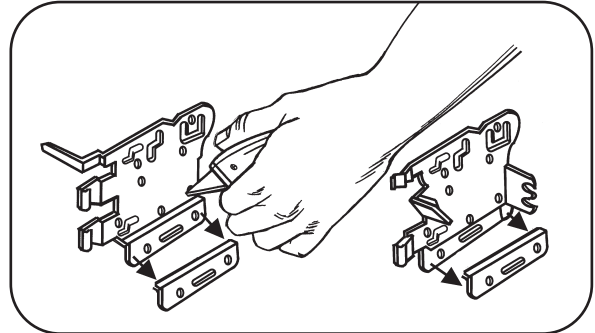
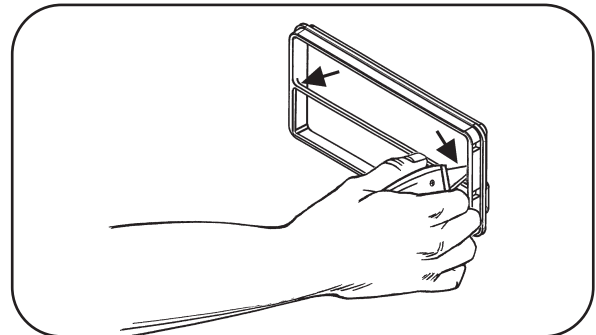
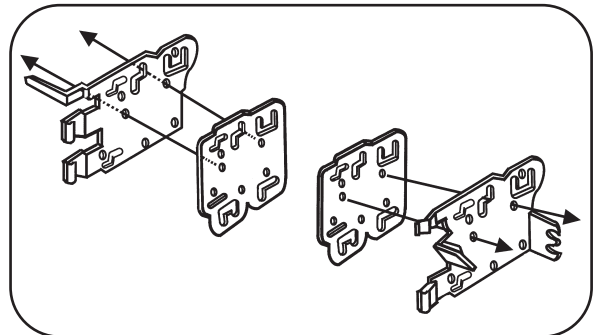
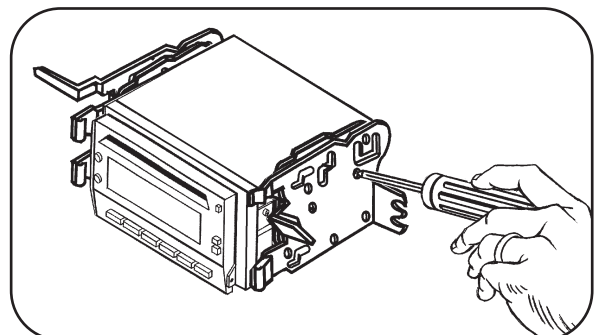
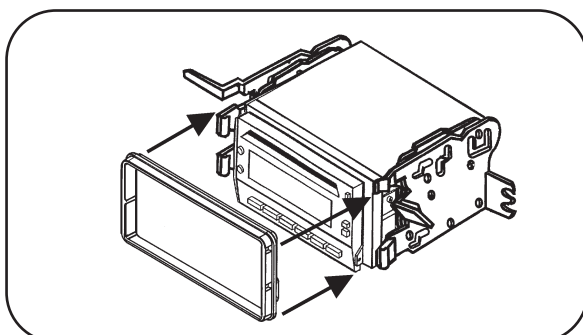
NOTE: *2005-2008 Matrix not applicable.*

- 1** Cut and remove the bottom portion (Displayed) of the mounting brackets. (Figure A)
- 2** Cut and remove the center bar from the DDIN faceplate. (Figure B)
- 3** Attach the ISO spacers to the mounting brackets by inserting the (4) bosses on each spacer into the (4) holes in each bracket. (Figure C)
- 4** Attach the mounting brackets to the DDIN head unit with the screws supplied with the unit. (Figure D)
- 5** Attach the DDIN faceplate over the head unit by snapping the bracket clips into the faceplate slots. (Figure E)

A

B

C

D

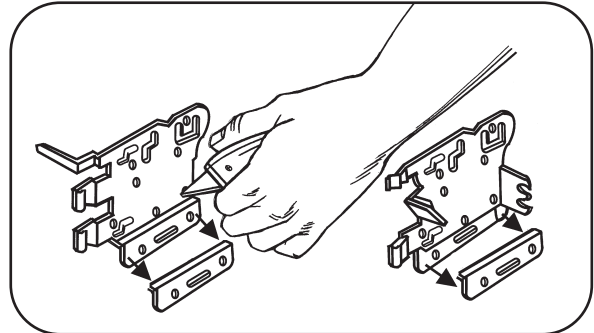
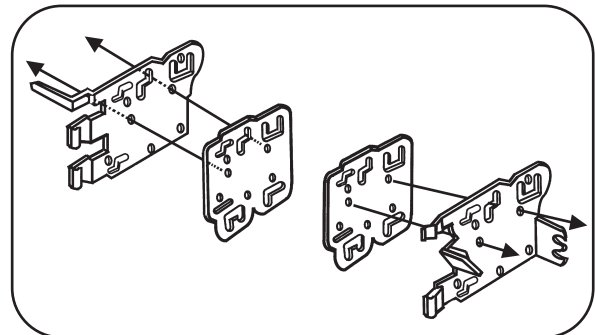
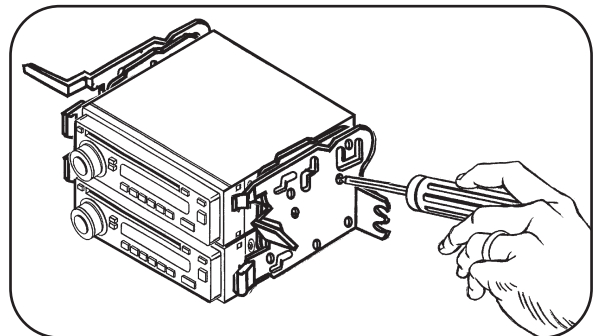
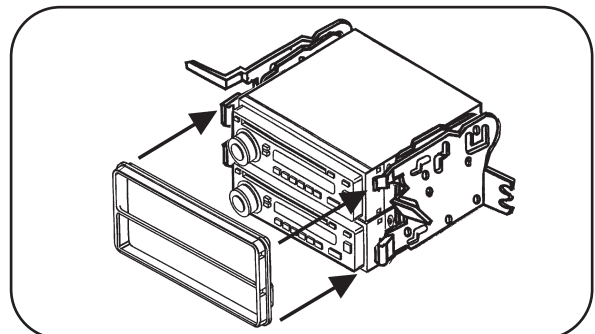
E

STACKED ISO DIN HEAD UNIT PROVISION

NOTE: *2005-2008 Matrix not applicable.*

- 1** Cut and remove the bottom portion (Displayed) of the mounting brackets. (Figure A)
- 2** Attach the ISO spacers to the mounting brackets by inserting the (4) bosses on each spacer into the (4) holes in each bracket. (Figure B)
- 3** Attach the mounting brackets to the DDIN head unit with the screws supplied with the unit. (Figure C)
- 4** Attach the DDIN faceplate over the head unit by snapping the bracket clips into the faceplate slots. (Figure D)

A

B

C

D

FINAL ASSEMBLY

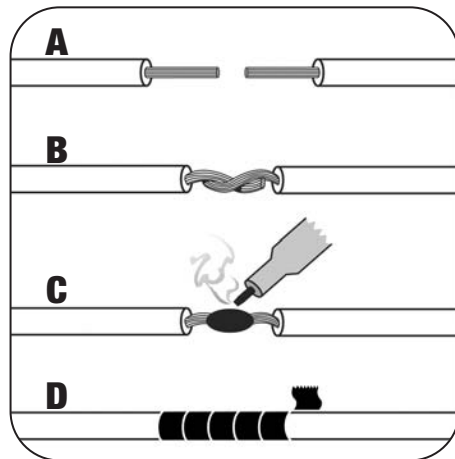
- 1 Locate the factory wiring harness in the dash and make the connection as shown. Metra recommends using the proper mating adapter and making the connections as shown. (Isolate and individually tape off the ends of any unused wires to prevent electrical short circuit.)
- 2 Re-connect the negative battery terminal and test the unit for proper operation.
- 3 Reassemble radio and dash assemblies in reverse order of disassembly.

FINAL WIRING CONNECTIONS

Make wiring connections using the EIA color code chart shown below and the instructions included with the head unit. Metra recommends making connections as shown below; Strip, Splice, Solder, Tape. Isolate and individually tape off ends of any unused wires to prevent electrical short circuit.



- A) Strip wire ends back 1/2"**
- B) Twist ends together**
- C) Solder**
- D) Tape**

METRA / EIA WIRING CODE

12V Ignition / Acc . . . Red	Right Front (+) Gray
12V Batt / Memory . . . Yellow	Right Front (-) Gray / Black
Ground Black*	Left Front (+) White
Power Antenna Blue	Left Front (-) White / Black
Amp Turn-On Blue / White	Right Rear (+) Violet
Amp Ground Black / White	Right Rear (-) Violet / Black
Illumination Orange	Left Rear (+) Green
Dimmer Orange / White	Left Rear (-) Green / Black

***NOTE:** When Black a wire is not present, ground radio to vehicle chassis.

All colors may not be present on all leads due to manufacturer's specifications.

INST998205



1-800-221-0932



www.metraonline.com

REV. 09/26/08

© COPYRIGHT 2004-08 METRA ELECTRONICS CORPORATION

INST99-8205