



Toyota Highlander (with factory NAV) 2008-2012

Visit MetraOnline.com for more detailed information about the product and up-to-date vehicle specific applications

KIT FEATURES

- DIN radio provision with pocket
- ISO DIN radio provision with pocket
- ISO DDIN radio provision
- Hazard button with passenger airbag and security light assembly included.
- Painted to match factory dash

KIT COMPONENTS

- A) Radio housing • B) ISO DIN brackets • C) ISO DIN trim plate • D) ISO DDIN brackets • E) ISO DDIN trim plate • F) Pocket • G) Radio housing brackets
- H) Hazard button harness (not shown)

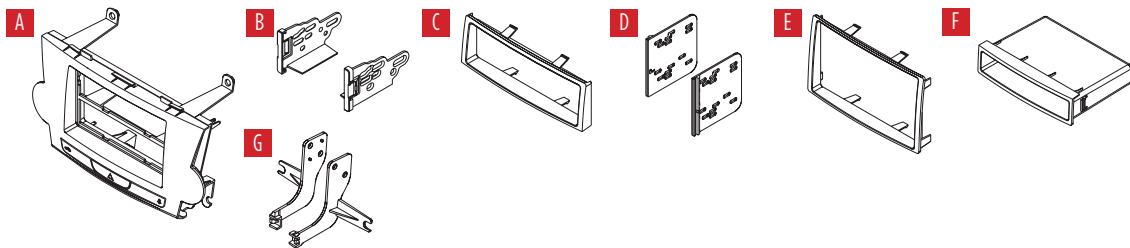

TABLE OF CONTENTS

Dash Disassembly	2
Kit Preparation.....	3-4
Kit Assembly	
–DIN radio provision with pocket	5
–ISO DIN radio provision with pocket.....	6
–ISO DDIN radio provision	7

WIRING & ANTENNA CONNECTIONS (sold separately)

Wiring Harness: 70-1761

See AXXESSINTERFACES.COM for all interface solutions.

Antenna Adapter: Not required

TOOLS REQUIRED

- Panel removal tool • Phillips screwdriver
- Cutting tool • 10mm socket wrench

Attention! With the key out of the ignition, disconnect the negative battery terminal before installing this product. Ensure that all installation connections are secure before cycling the ignition to test this product.

DASH DISASSEMBLY

1. Unclip and remove the a/c vent panel. (Figure A)
2. Unclip, unplug, and remove the climate control panel. (Figure B)
3. Remove (4) 10mm bolts securing the radio. Slide the radio out, then unplug and remove the radio/display assembly. (Figure C)

Note: Non-NAV radio shown in dash disassembly drawings

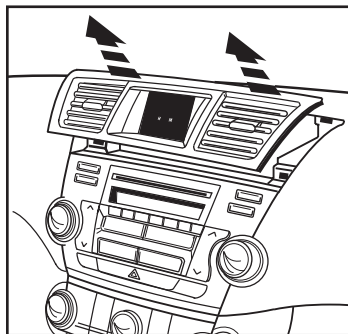

(Figure A)

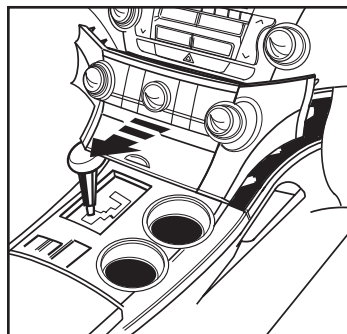

(Figure B)

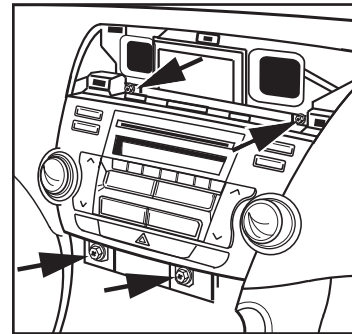

(Figure C)

Continue to Kit Preparation

KIT PREPARATION

From the factory radio/display assembly:

1. Remove (2) Phillips screws securing the display panel, then remove. (Figure A)
2. Remove (4) panel clips. (Figure B)

Continued on the next page

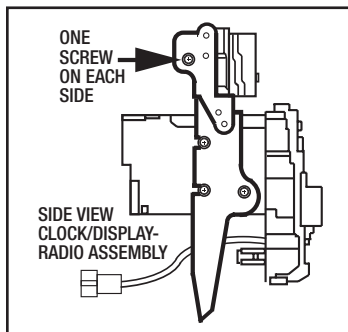

(Figure A)

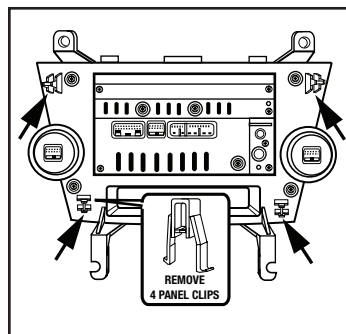

(Figure B)

KIT PREPARATION (CONT.)

To the 99-8274 radio housing:

4. Attach the **radio housing brackets**. (Figure C)
Note: Make sure the leg on the bracket points outward.
5. Slide the factory display panel into the **radio housing**, then secure using the factory screws. (Figure D)
6. Attach the (4) factory panel clips removed in step 3. (Figure E)
7. Plug in the supplied harness from the hazard assembly to the original hazard connection from the vehicle.

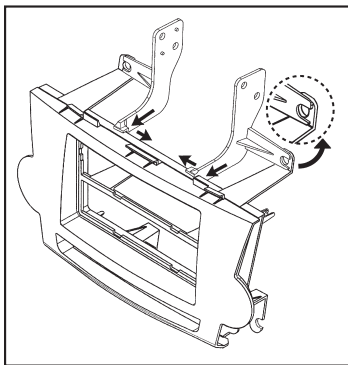

(Figure C)

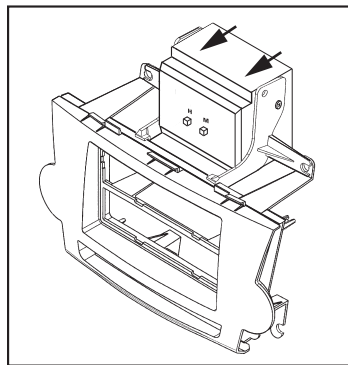

(Figure D)

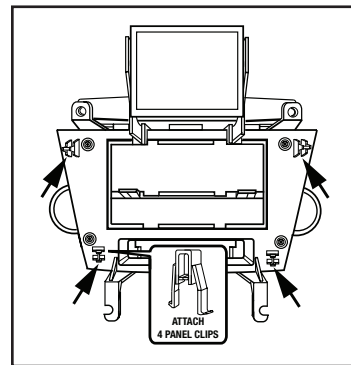

(Figure E)

Continue to Kit Assembly

KIT ASSEMBLY

DIN radio provision with pocket

1. Remove the metal DIN sleeve from the aftermarket radio.
2. Slide the sleeve into the **radio housing** assembly and secure by bending the metal locking tabs outward. (Figure A)
3. Slide the radio back into the sleeve until it snaps into place. (Figure B)
4. Snap the **pocket** into the radio housing assembly. (Figure C)
5. Locate the factory wiring harness and antenna connector in the dash. Complete all necessary connections to the radio and vehicle. Metra recommends using the proper mating adapter from Metra or AXCESS. Test the radio and vehicle for proper operation.
6. Reassemble the dash in reverse order of disassembly.

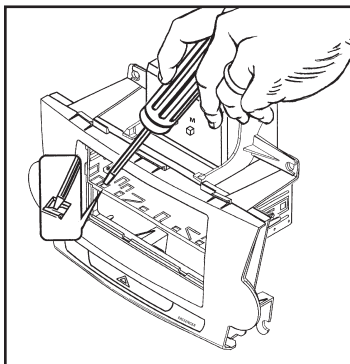

(Figure A)

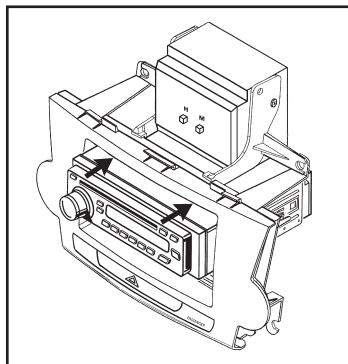

(Figure B)

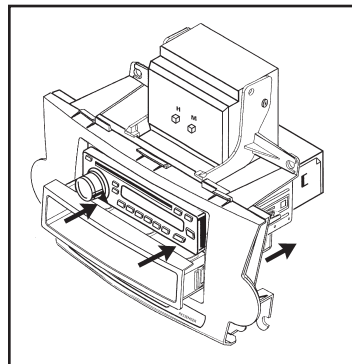

(Figure C)

KIT ASSEMBLY

ISO DIN radio provision with pocket

1. Remove the metal DIN sleeve and trim ring from the aftermarket radio.
2. Secure the **ISO DIN brackets** to the radio using the screws supplied with the radio. (Figure A)
3. Slide the radio into the radio housing assembly until it snaps into place. (Figure B)
4. Snap the **ISO DIN trim plate** onto the front of the **radio housing**. (Figure B)
5. Snap the **pocket** into the radio housing assembly (Figure C)
6. Locate the factory wiring harness and antenna connector in the dash. Complete all necessary connections to the radio and vehicle. Metra recommends using the proper mating adapter from Metra or AXCESS. Test the radio and vehicle for proper operation.
7. Reassemble the dash in reverse order of disassembly.

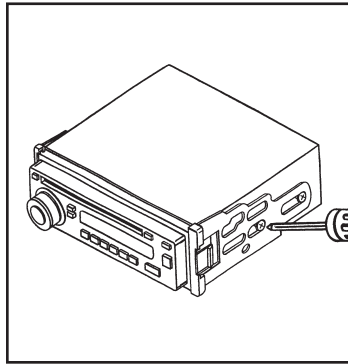

(Figure A)

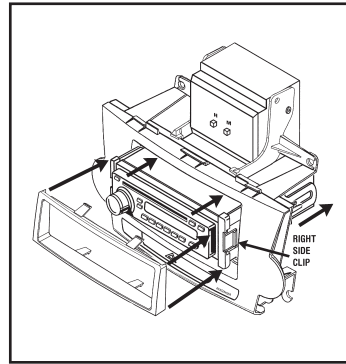

(Figure B)

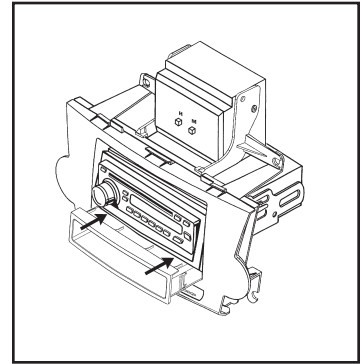

(Figure C)

KIT ASSEMBLY

ISO DDIN radio provision

1. Cut and remove the center bar from the **radio housing**. (Figure A)
2. Attach the **ISO DDIN brackets** to the inside opening of the radio housing assembly. (Figure B)
3. Slide the radio into the radio housing assembly, then secure using screws supplied with the radio. (Figure C)
4. Snap the **ISO DDIN trim plate** onto the front of the radio housing assembly. (Figure C)
5. Locate the factory wiring harness and antenna connector in the dash. Complete all necessary connections to the radio and vehicle. Metra recommends using the proper mating adapter from Metra or AXXESS. Test the radio and vehicle for proper operation.
6. Reassemble the dash in reverse order of disassembly.

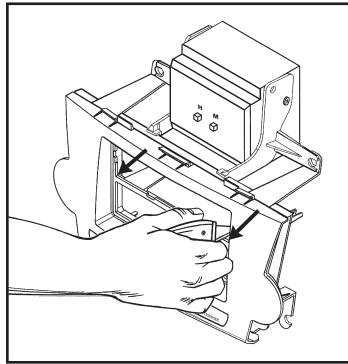

(Figure A)

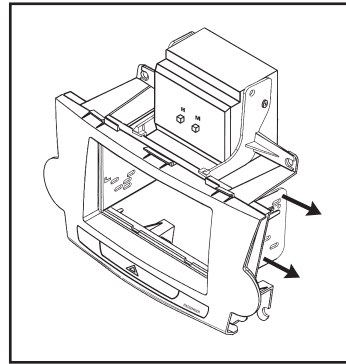

(Figure B)

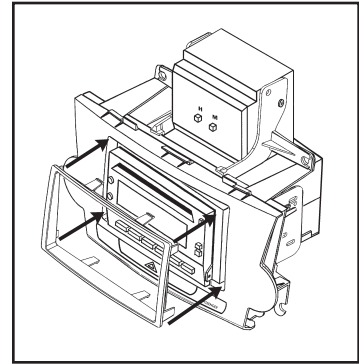

(Figure C)



99-8274
INSTALLATION INSTRUCTIONS



Having difficulties? We're here to help.



Contact our Tech Support line at:

386-257-1187



Or via email at:

techsupport@metra-autosound.com

Tech Support Hours (Eastern Standard Time)

Monday - Friday: 9:00 AM - 7:00 PM

Saturday: 10:00 AM - 5:00 PM

Sunday: 10:00 AM - 4:00 PM



**Metra recommends MECP
certified technicians**