



INSTALLATION INSTRUCTIONS FOR PART 99-9223

APPLICATIONS

Volvo S60/V70 2001-2004 99-9223



KIT FEATURES

- DIN head unit provision with pocket

KIT COMPONENTS

- A) Radio housing

A

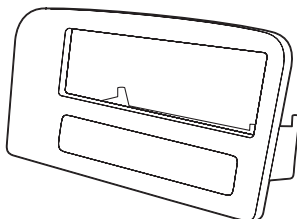

WIRING & ANTENNA CONNECTIONS (sold separately)

Wiring Harness:

- 70-9221 - Harness for select Volvo vehicles 1999-2003

Antenna Adapter:

- 40-VL10 - Adapter cable for select Volvo 1999-up

TOOLS REQUIRED

- Phillips screwdriver • T-25 Torx driver

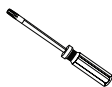
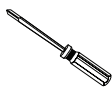

METRA. THE WORLD'S BEST KITS.™



1-800-221-0932



metraonline.com

© COPYRIGHT 2004-2011 METRA ELECTRONICS CORPORATION

REV. 5/1/12



99-9223

Table of Contents

Dash Disassembly

– Volvo S60 2001-2004	3
– Volvo V70 2001-2004	3

Kit Assembly

– DIN head unit provision with pocket	4-5
---	-----

CAUTION: *Metra recommends disconnecting the negative battery terminal before beginning any installation. All accessories, switches, and especially air bag indicator lights must be plugged in before reconnecting the battery or cycling the ignition.*

Note: *Refer to the instructions included with the aftermarket radio.*



KNOWLEDGE IS POWER

Enhance your installation and fabrication skills by enrolling in the most recognized and respected mobile electronics school in our industry. Log onto www.installerinstitute.com or call 800-354-6782 for more information and take steps toward a better tomorrow.



Metra recommends MECP certified technicians

Volvo S60/V70 2001-2004

1. Unsnap gearshift trim bezel and slide back. (Figure A)
2. Remove (2) T-25 Torx from climate control assembly, angle the climate control panel out, insert fingers between the console and climate panel and pull down at the same angle. Remove the panel (some force may be required). (Figure B)
3. Remove (2) T-25 Torx from radio bottom in climate control cavity to remove radio. (Figure C)

Continue to kit assembly

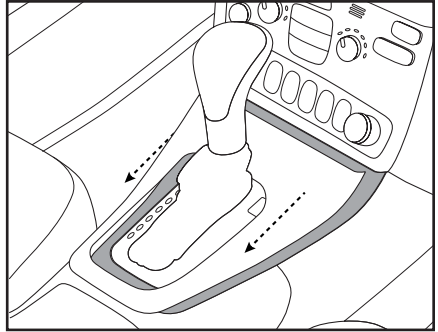

(Figure A)

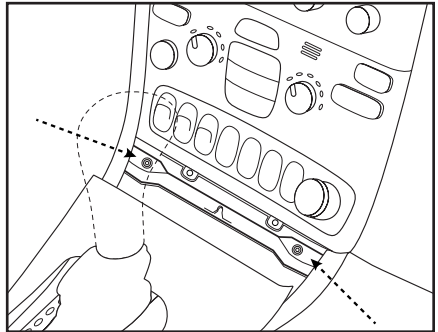

(Figure B)

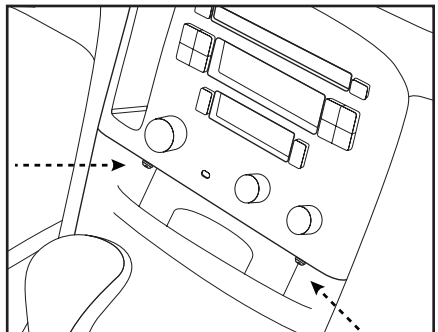

(Figure C)



Kit Assembly 99-9223

DIN head unit provision with pocket

1. With a Phillips screwdriver remove the kit rear support bracket. (Figure A)
2. After removing radio, with a T-25 Torx driver, remove (5) screws from radio bracket. (Figure B)
3. Depress snaps on top and bottom of pocket to remove from bracket. (Figure C)
4. Slide radio bracket off of radio.

Continue on next page

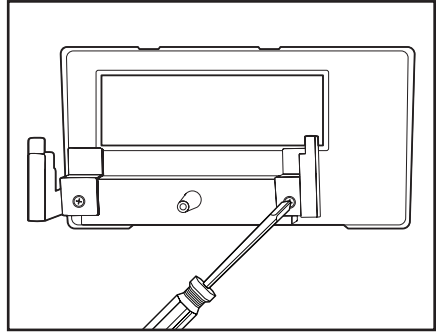

(Figure A)

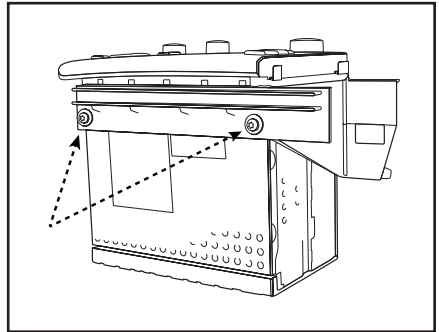

(Figure B)

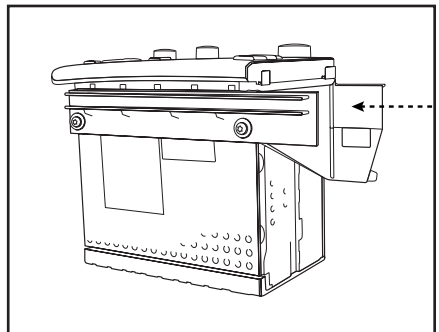

(Figure C)



Kit Assembly 99-9223

DIN head unit provision with pocket

5. Snap the radio housing into radio bracket and replace rear support brackets previously removed. (Figure D)
6. Slide the DIN cage into the radio opening, secure by bending the metal locking tabs down. (Figure E)
7. Slide the DIN unit (radio) into the cage until its secure. (Figure F)
8. Locate the factory wiring harness in the dash. Metra recommends using the proper mating adapter from Metra or AXCESS. Re-connect the negative battery terminal and test the unit for proper operation.
9. Reassemble dash in reverse order of disassembly.

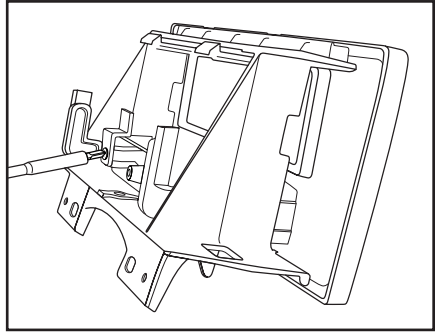

(Figure D)

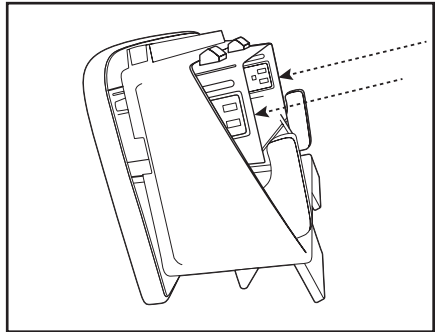

(Figure E)

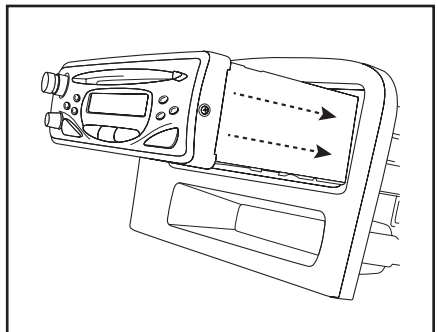

(Figure F)



INSTALLATION INSTRUCTIONS FOR PART 99-9223

REV. 5/1/12

METRA. THE WORLD'S BEST KITS.™



1-800-221-0932



metraonline.com

© COPYRIGHT 2004-2011 METRA ELECTRONICS CORPORATION



INSTRUCCIONES DE INSTALACIÓN PARA LA PIEZA 99-9223

APLICACIONES

Volvo S60/V70 2001-2004 99-9223



CARACTERÍSTICAS DEL KIT

- Provisión de unidad central DIN con bolsillo

COMPONENTES DEL KIT

- A) Alojamiento del radio

A

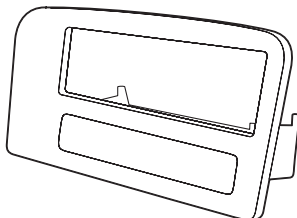

CABLEADO Y CONEXIONES DE ANTENA (se venden por separado)

Arnés de cableado:

- 70-9221 - Arnés para ciertos vehículos Volvo 1999-2003

Adaptador de antena:

- 40-VL10 - Adaptador para seleccionar Volvo 1999 y más

HERRAMIENTAS REQUERIDAS

- Destornillador Phillips • Destornillador Torx

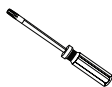
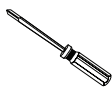

METRA. THE WORLD'S BEST KITS.™



1-800-221-0932



metraonline.com

© COPYRIGHT 2004-2011 METRA ELECTRONICS CORPORATION

REV. 5/2/12



99-9223

Indice

Desmontaje del tablero

– Volvo S60 2001-2004	3
– Volvo V70 2001-2004	3

Ensamble del kit

– Provisión de unidad central DIN con bolsillo	4-5
--	-----

PRECAUCIÓN: *Metra recomienda desconectar el terminal negativo de la batería antes de comenzar cualquier instalación. Todos los accesorios, interruptores y, especialmente, las luces indicadoras de airbag deben estar enchufados antes de volver a conectar la batería o comenzar el ciclo de ignición.*

Nota: *Remítase a las instrucciones incluidas con el radio de posventa.*



EL CONOCIMIENTO ES PODER

Mejore sus habilidades de instalación y fabricación inscribiéndose en la escuela de dispositivos electrónicos móviles más reconocida y respetada de nuestra industria. Regístrese en www.installerinstitute.com o llame al 800-354-6782 para obtener más información y avance hacia un futuro mejor.



Metra recomienda técnicos con certificación del Programa de Certificación en Electrónica Móvil (Mobile Electronics Certification Program, MECP).

Volvo S60/V70 2001-2004

1. Suelte a presión el bisel de la moldura de la palanca de cambios y deslícelo hacia atrás. (Figura A)
2. Quite (2) T-25 Torx del ensamble de control de clima, saque en ángulo el panel del control de clima, inserte los dedos entre la consola y el panel de clima y jale hacia abajo en el mismo ángulo. Quite el panel (puede requerirse un poco de fuerza). (Figura B)
3. Quite (2) T-25 Torx de la parte de abajo del radio en la cavidad del control de clima para quitar el radio. (Figura C)

Continuará al ensamble del kit

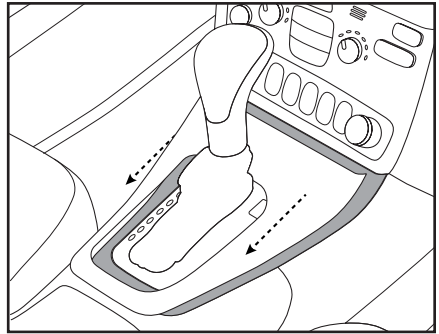

(Figura A)

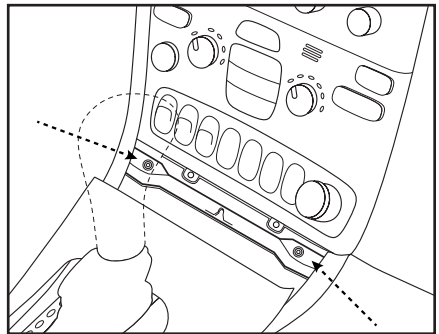

(Figura B)

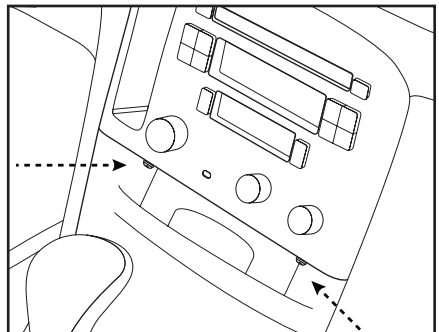

(Figura C)

Provisión de unidad central DIN con bolsillo

1. Con un destornillador Phillips, quite el soporte de apoyo trasero del kit. (Figura A)
2. Después de quitar el radio, con un destornillador T-25 Torx, quite los (5) tornillos del soporte del radio. (Figura B)
3. Aplaste hacia abajo las pestañas de arriba y abajo del bolsillo para quitarlo del soporte. (Figura C)
4. Deslice el soporte hasta sacarlo del radio.

Continúa en la página

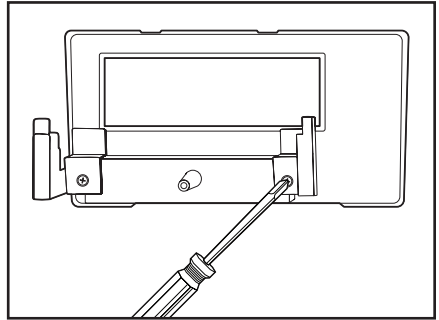

(Figura A)

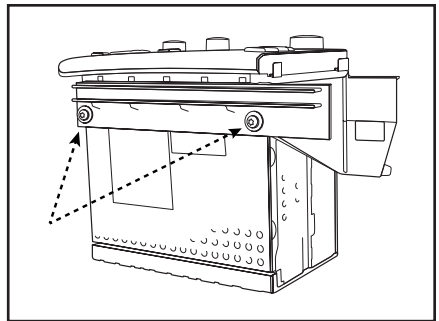

(Figura B)

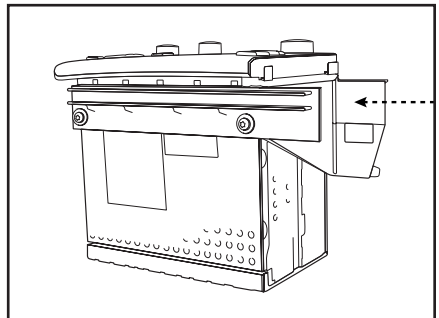

(Figura C)

Provisión de unidad central DIN con bolsillo

5. Coloque a presión la carcasa del radio en el soporte del radio y vuelva a colocar los soportes de apoyo trasero que quitó anteriormente. (Figura D)
6. Deslice la reja DIN en la apertura del radio, sujétela doblando hacia abajo las pestañas de metal. (Figura E)
7. Deslice la unidad DIN (radio) en la reja hasta que quede firme. (Figura F)
8. Ubique el arnés del cableado de fábrica en el tablero. Metra recomienda usar el adaptador de acoplamiento adecuado de Metra o AXCESS. Vuelva a conectar el terminal negativo de la batería y pruebe la unidad para verificar que funcione correctamente.
9. Vuelva a montar el tablero en forma inversa al desmontaje.

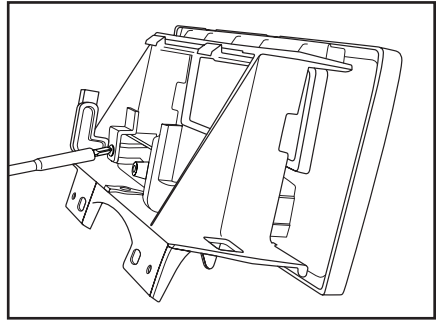

(Figura D)

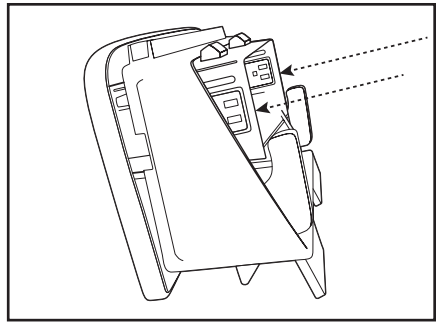

(Figura E)

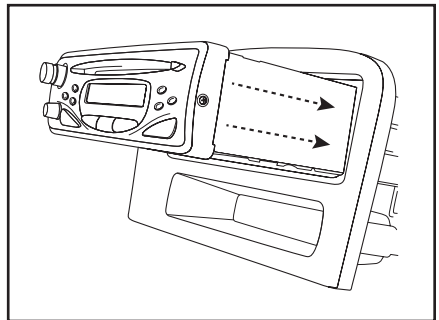

(Figura F)



INSTRUCCIONES DE INSTALACIÓN PARA LA PIEZA 99-9223

REV. 5/2/12

METRA. THE WORLD'S BEST KITS.™



1-800-221-0932



metraonline.com

© COPYRIGHT 2004-2011 METRA ELECTRONICS CORPORATION