



INTERFACE COMPONENTS

- AXAMP-CH8 Amplifier Integration interface
- LD-DSP-RPAD2
- AXAMP-CH8 vehicle T-harness
- Bass knob

APPLICATIONS

Visit AxxessInterfaces.com for current application list

Amplifier Integration Interface Fits Chrysler Select Models 2021-Up

INTERFACE FEATURES

- Designed for both amplified and non-amplified models
- Provides 6 channels of 5-volt RMS audio
- Channels 5 & 6 are non-fading full range output
- Includes plug-n-play harnessing
- Simple behind the radio installation
- Dual colored LED feedback
- Input Power handling 50 Watts per channel
- Amp on turn-on output is rated at 250mA
- 2 channel S/PDIF out (Fronts)

www.MetraOnline.com

For **Dash Disassembly Instructions**, refer to metraonline.com. Enter the year, make, and model of the vehicle in the **Vehicle Fit Guide for Radio Install kits**.



TABLE OF CONTENTS

Installation & Installation Options.....	2
Adding Amp/Amps to a Factory System	
Non-amplified.....	3
Amplified.....	4
Rebooting the U-Connect Radio	5
Troubleshooting: LED Feedback	6

TOOLS & INSTALLATION ACCESSORIES REQUIRED

- Crimping tool and connectors, or solder gun, solder, and heat shrink
- Tape
- Wire cutter
- Zip-ties
- Multimeter

Visit AxxessInterfaces.com for more detailed information about the product and up-to-date vehicle specific applications.

ATTENTION: With the key out of the ignition, disconnect the negative battery terminal before installing this product. Ensure that all installation connections, especially the air bag indicator lights, are plugged in before reconnecting the battery or cycling the ignition to test this product.

NOTE: Refer also to the instructions included with the aftermarket accessory before installing this device.

INSTALLATION OPTIONS

Adding a full-range amp and subwoofer to a factory system:

This feature offers the ability to add a full-range amp and sub to a factory system, whether amplified* or non-amplified. (Refer to **Page 3**)

* For amplified models the amp must be bypassed/unplugged. Refer to www.MetraOnline.com for the vehicle specific amplifier bypass harness.

Note: The interface provides a 12-volt 1-amp output to turn on aftermarket amp(s). If installing multiple amps, an SPDT automotive relay will be required if the amp turn-on current of all amps combined exceeds 1-amp. Use Metra part number E-123 (sold separately) for best results.

INSTALLATION

1. Disassemble the dash, unplug all connectors, and then remove the factory radio.*
 2. Install the **AXAMP-CH8 vehicle T-harness** to the vehicle and make all necessary connections, but leave the amp turn-on wire disconnected.
 3. Plug the **AXAMP-CH8 vehicle T-harness** to the **AXAMP-CH8 interface**.
 4. Plug the **AXAMP-CH8 interface harness** to the **AXAMP-CH8 interface**.
 5. Connect the amp turn-on wire.
 6. Adjust your aftermarket amplifier to a desired listening level.
 7. The Bassknob is used to adjust the output of channels 5 & 6 of the AXAMP.
Adjustment is as follows:
Counterclockwise turn lowers the volume of channels 5 & 6.
Clockwise turn raises the volume of channels 5 & 6.
- * For dash disassembly instructions, refer to www.MetraOnline.com. Enter the year, make, and model of the vehicle in the **Vehicle Fit Guide** and find instructions under **Metra Radio Install kits**.

ADDING AMPLIFIER/AMPLIFIERS TO A FACTORY SYSTEM

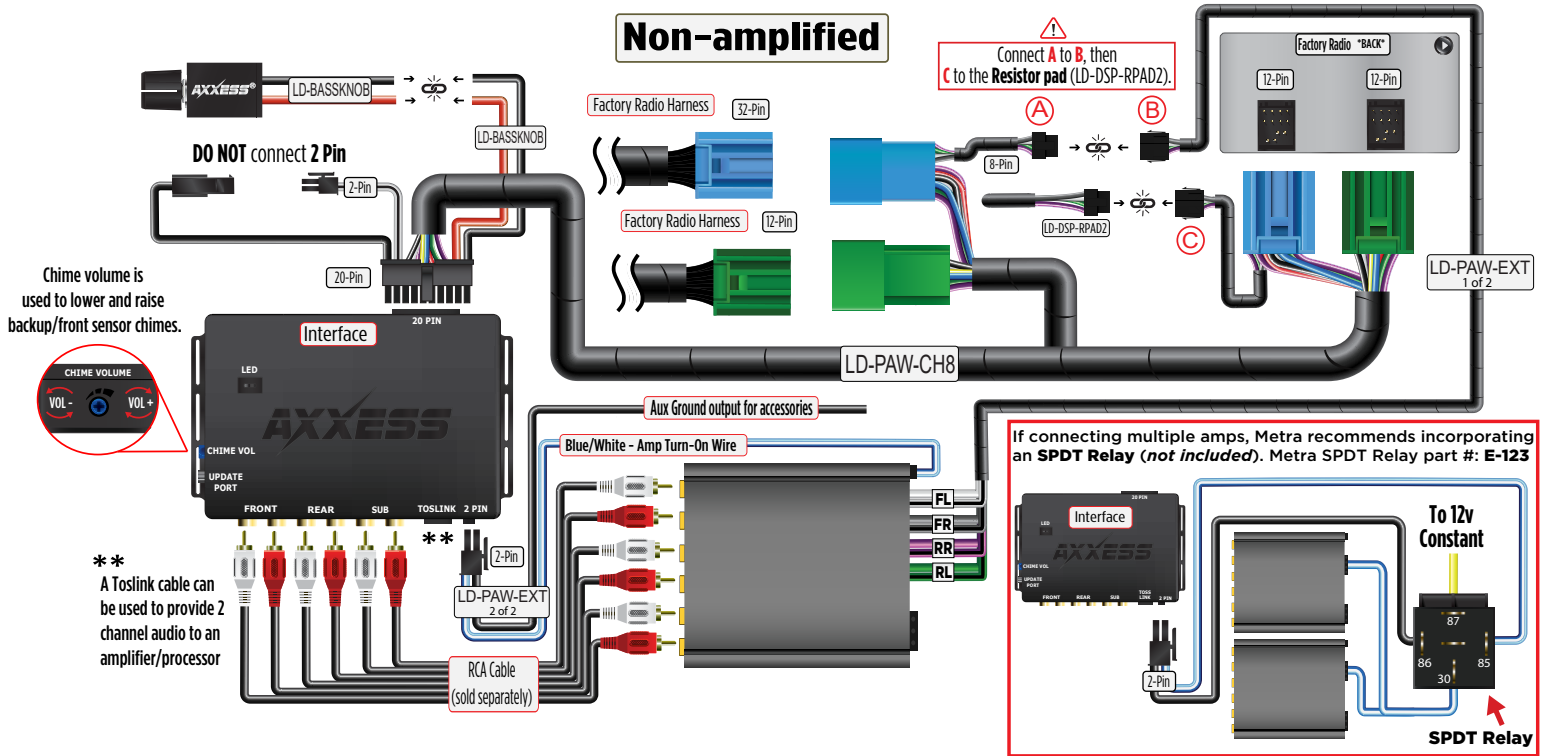

ADDING AMPLIFIER/AMPLIFIERS TO A FACTORY SYSTEM CONT.

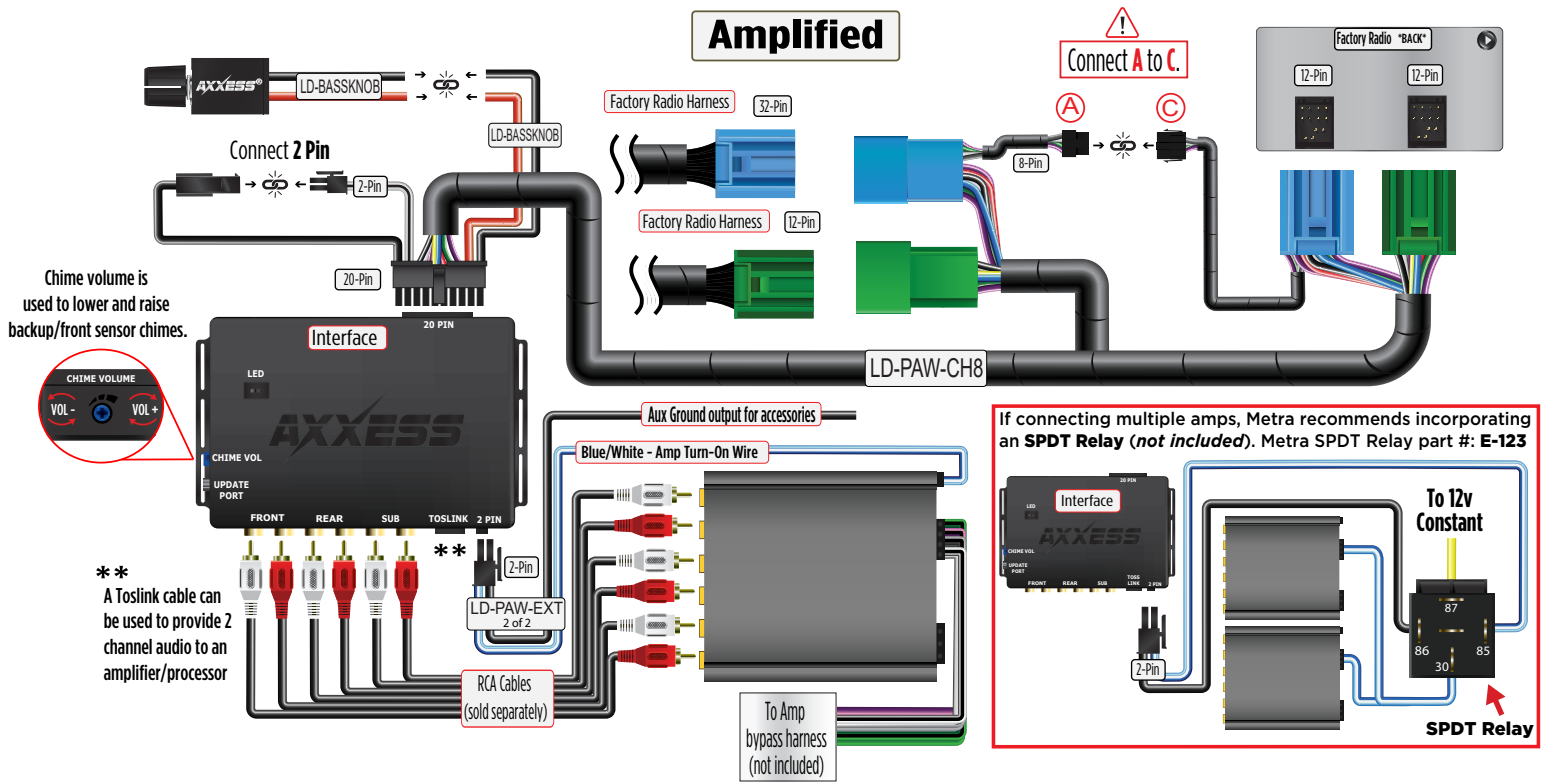

REBOOTING THE U-CONNECT RADIO

- The factory **U-Connect Radio** will require a reboot process to accept the aftermarket interface/or add a camera. Disconnecting the main harness to install a T-harness and repowering the radio may cause **U-Connect Radio** to program as a different model of vehicle than it was programmed to originally. Below are the different **U-Connect** initial **Splash/Boot Up** screens for vehicle types.

SPLASH/BOOT UP COLORS

Chrysler: Blue

Dodge/Ram: Red

Jeep: Orange

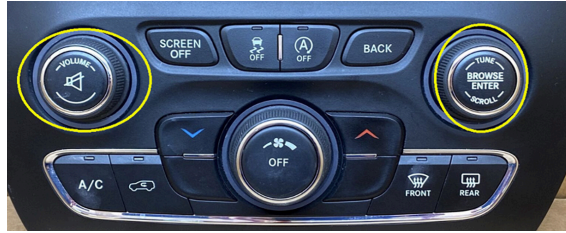

REBOOTING STEPS

1. Turn the Key or Press **Push to Start** Button to the ACC position.
DO NOT press brake on **Push to Start** vehicles.
2. Press the Volume **PWR/MUTE** button and **TUNE/ENTER** button for 10-16 seconds, until the radio reboots.
3. Let go once the radio reboots, now you have successfully rebooted your factory radio.

TROUBLESHOOTING

Final LED Feedback

At the end of programming the LED will turn **Solid Green** which indicates programming was successful. If the LED didn't turn **Solid Green**, reference the list below to understand which programming section the problem may stem from.

Blink Rate	Condition/Status
Solid Green	All Good
Solid Red	Missing Can Frames
Blink Red	Clipping Output
Green/Red	Missing Adv. (Comm Frames)

Scan QR Code



Further troubleshooting steps and information can be located at:

axcessinterfaces.com/product/AXAMP-CH8

Having difficulties? We're here to help.



Contact our Tech Support line at:
386-257-1187



Or via email at:
techsupport@metra-autosound.com

Tech Support Hours (Eastern Standard Time)

Monday - Friday: 9:00 AM - 7:00 PM

Saturday: 10:00 AM - 5:00 PM

Sunday: 10:00 AM - 4:00 PM



Metra recommends MECP
certified technicians