



INTERFACE COMPONENTS

- AXAMP-TY4 Amplifier Integration interface
- AXAMP-TY4 vehicle T-harness
- Bass knob

APPLICATIONS

Visit AxxessInterfaces.com for current application list

Amplifier Integration Interface Fits Toyota **2011-2022**

INTERFACE FEATURES

- Designed for amplified models
- Provides 6 channels of 5-volt RMS audio
- Non-fading full range output (Channels 5 & 6)
- Includes plug-n-play harnessing
- Simple behind the radio installation
- No programming required
- Dual colored LED
- Input: 50 Watts per channel
- Amp turn-on trigger (DC) 250mA
- 2 channel S/PDIF out (Front)

www.MetraOnline.com

For **Dash Disassembly Instructions**, refer to [Metraonline.com](http://www.MetraOnline.com). Enter the year, make, and model of the vehicle in the **Vehicle Fit Guide** for **Radio Install kits**.



TABLE OF CONTENTS

Installation & Installation Options.....	2
Adding Amp(s) to a Factory System.....	3
Troubleshooting.....	4

TOOLS & INSTALLATION ACCESSORIES REQUIRED

- Crimping tool and connectors, or solder gun, solder, and heat shrink
- Tape
- Wire cutter
- Zip-ties
- Multimeter

ATTENTION: With the key out of the ignition, disconnect the negative battery terminal before installing this product. Ensure that all installation connections, especially the air bag indicator lights, are plugged in before reconnecting the battery or cycling the ignition to test this product.

NOTE: Refer also to the instructions included with the aftermarket accessory before installing this device.

INSTALLATION OPTIONS

Adding a full-range amplifier and subwoofer to a factory system:

This feature offers the ability to add a full-range amp and sub to a factory system.* (Refer to **Page 3**)

* For amplified models the amp must be bypassed/unplugged. Refer to www.MetraOnline.com for the vehicle specific amplifier bypass harness.

Note: The interface provides a 12-volt 1-amp output to turn on aftermarket amp(s). If installing multiple amps, an SPDT automotive relay will be required if the amp turn-on current of all amps combined exceeds 1-amp. Use Metra part number E-123 (sold separately) for best results.

INSTALLATION

1. Disassemble the dash, unplug all connectors, and then remove the factory radio.*
2. Install the **AXAMP-TY4 vehicle T-harness** to the vehicle and make all necessary connections, but leave the amp turn-on wire disconnected.
3. Plug the **AXAMP-TY4 vehicle T-harness** to the **AXAMP-TY4 interface**.
4. Plug the **AXAMP-TY4 interface harness** to the **AXAMP-TY4 interface**.
5. Connect the amp turn-on wire.
6. Adjust your aftermarket amplifier to a desired listening level.
7. The Bassknob is used to adjust the output of channels 5 & 6 of the AXAMP.
Adjustment is as follows:
Counterclockwise turn lowers the volume of channels 5 & 6.
Clockwise turn raises the volume of channels 5 & 6.

*For dash disassembly instructions, refer to www.MetraOnline.com. Enter the year, make, and model of the vehicle in the **Vehicle Fit Guide** and find instructions under **Metra Radio Install kits**.

ADDING AMPLIFIER/AMPLIFIERS TO A FACTORY SYSTEM

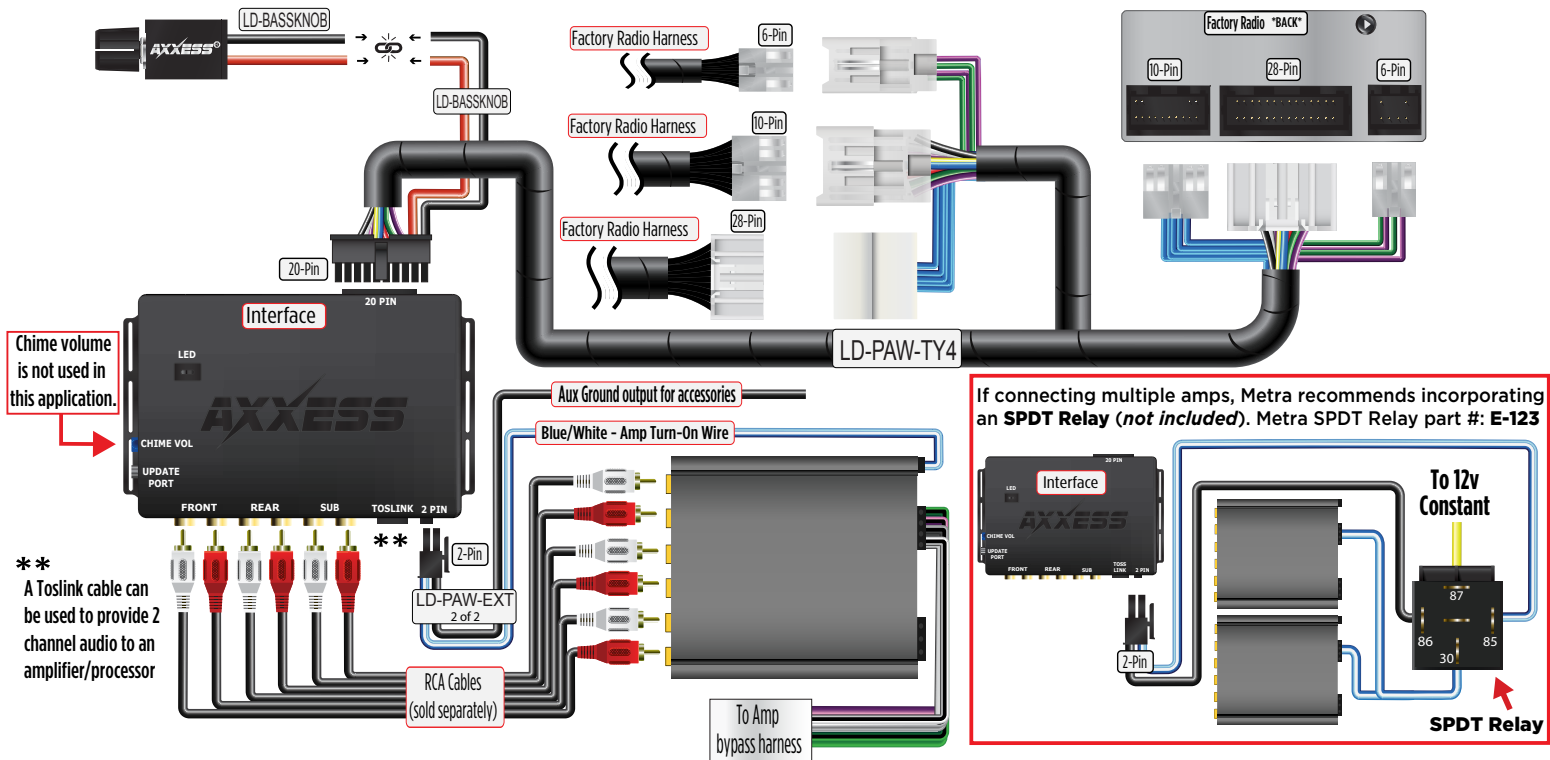

TROUBLESHOOTING

Final LED Feedback

At the end of programming the LED will turn **Solid Green** which indicates programming was successful. If the LED didn't turn **Solid Green**, reference the list below to understand which programming section the problem may stem from.

Blink Rate	Condition/Status
Solid Green	All Good
Solid Red	Missing Can Frames
Blink Red	Clipping Output
Green/Red	Missing Adv. (Comm Frames)

Scan QR Code



Further troubleshooting steps and information can be located at:

axcessinterfaces.com/product/AXAMP-TY4

Having difficulties? We're here to help.



Contact our Tech Support line at:
386-257-1187



Or via email at:
techsupport@metra-autosound.com

Tech Support Hours (Eastern Standard Time)

Monday - Friday: 9:00 AM - 7:00 PM

Saturday: 10:00 AM - 5:00 PM

Sunday: 10:00 AM - 4:00 PM



Metra recommends MECP
certified technicians