



## Volkswagen Data Interface 2015-Up

Visit [AxxessInterfaces.com](http://AxxessInterfaces.com) for more detailed information about the product and up-to-date vehicle specific applications

### INTERFACE FEATURES

- Provides accessory power (12-volt 10-amp)
- Retains R.A.P. (Retained Accessory Power)
- Provides NAV outputs (parking brake, reverse, speed sense)
- For use in non-amplified systems, or when replacing an amplified system
- 48-inch leads for remote tuner location
- Pre-wired AXSWC harness (AXSWC sold separately)
- Retains the factory backup camera
- Retains balance and fade
- Micro-B USB updatable

### INTERFACE COMPONENTS

- AXDI-VW2 interface
- LD-XSVI-9006NAV harness

### APPLICATIONS

#### Volkswagen

Beetle.....	2016-2019	Jetta GLI.....	2016-2018
Golf Series.....	2015-Up	Passat.....	2016-Up
Jetta.....	2016-2019	Tiguan.....	2016-2017

### TABLE OF CONTENTS

Connections: LD-XSVI-9006NAV.....	2
Installation.....	3
Programming.....	3

### TOOLS REQUIRED

- Crimping tool and connectors, or solder gun, solder, and heat shrink
- Tape
- Wire cutter
- Zip ties

**ATTENTION:** With the key out of the ignition, disconnect the negative battery terminal before installing this product. Ensure that all installation connections, especially the air bag indicator lights, are plugged in before reconnecting the battery or cycling the ignition to test this product.

**NOTE:** Refer also to the instructions included with the aftermarket radio.

## CONNECTIONS: LD-XSVI-9006NAV

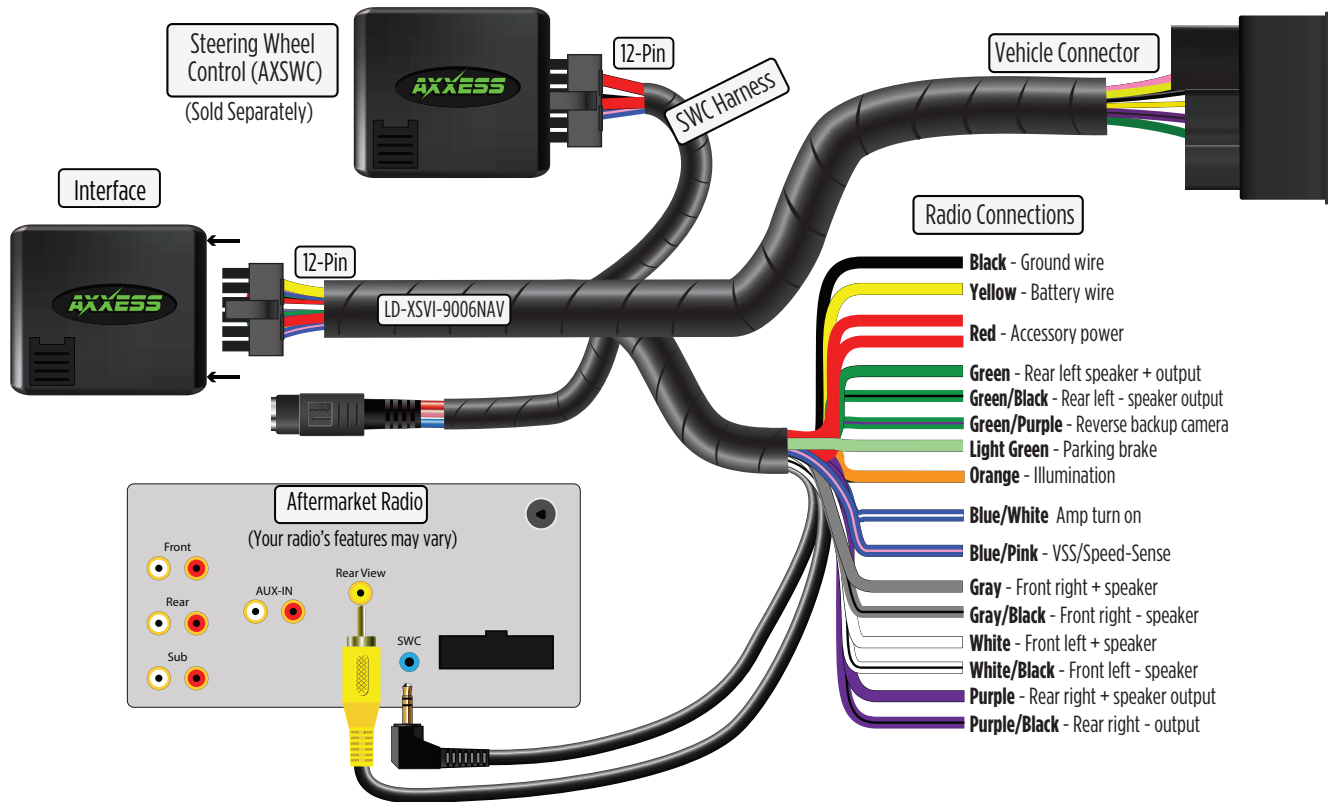

## INSTALLATION

### With the key in the off position:

1. Connect the **AXDI-VW2 harness** into the interface, and then to the wiring harness in the vehicle.

**Note:** The harness will connect to the harness removed from the disc drive located in the glove box for remote tuner applications.

2. If an **AXSWC** (sold separately) will be used, do not connect it until the interface is programmed and fully functional.

## PROGRAMMING

**Attention!** If the interface ever loses power, the following steps will need to be performed again. Please ensure that the owner of the vehicle knows this.

1. Turn the key (or push-to-start button) to the ignition position and wait until the radio comes on.

**Note:** If the radio does not come on within 60 seconds, turn the key to the off position, disconnect the interface, check all connections, reconnect the interface, and then try again.

2. Turn the key (or push-to-start button) to the off position, then to the accessory position. Test all functions of the installation for proper operation, before reassembling the dash.



# AXDI-VW2

INSTALLATION INSTRUCTIONS



Having difficulties? We're here to help.



Contact our Tech Support line at:

**386-257-1187**



Or via email at:

[techsupport@metra-autosound.com](mailto:techsupport@metra-autosound.com)

### Tech Support Hours (Eastern Standard Time)

Monday - Friday: 9:00 AM - 7:00 PM

Saturday: 10:00 AM - 5:00 PM

Sunday: 10:00 AM - 4:00 PM



### KNOWLEDGE IS POWER

Enhance your installation and fabrication skills by enrolling in the most recognized and respected mobile electronics school in our industry. Log onto [www.installerinstitute.com](http://www.installerinstitute.com) or call 800-354-6782 for more information and take steps toward a better tomorrow.



**Metra recommends MECP  
certified technicians**