



## Mitsubishi Select Models 2007-2013 Amplifier Interface

### INTERFACE FEATURES

- Retains the factory amplifier
- Provides multimedia wires (parking brake, reverse, and speed sense)
- RCA level input
- Retains balance and fade

### INTERFACE COMPONENTS

- AXTO-MI2 interface
- AXTO-MI2 harness
- 16-pin harness with stripped leads and RCA jacks

For Dash Disassembly Instructions, scan QR Code or refer to [Metraonline.com](http://Metraonline.com). Enter the year, make, and model of the vehicle in the **Vehicle Fit Guide for Radio Install kits**.

Metraonline.com



### APPLICATIONS

<b>Mitsubishi</b>	
Lancer .....	2008-2013
Outlander Sport .....	2011-2013
Outlander.....	2007-2013

### TABLE OF CONTENTS

Connections.....	2
Initializing and Adjusting the AXTO-MI2.....	3
QR Code for AXSWC	
Connections/Programming .....	3
AXSWC Wiring Guide .....	4

Visit [MetraOnline.com](http://MetraOnline.com) for more detailed information about the product and up-to-date vehicle specific applications

### TOOLS REQUIRED

- Cutting tool
- Crimping tool
- Tape
- Small flat-blade screwdriver
- Connectors (example: butt-connectors, bell caps, etc.)

**ATTENTION:** With the key out of the ignition, disconnect the negative battery terminal before installing this product. Ensure that all installation connections, especially the air bag indicator lights, are plugged in before reconnecting the battery or cycling the ignition to test this product.  
**NOTE:** Refer also to the instructions included with the aftermarket radio.

# CONNECTIONS

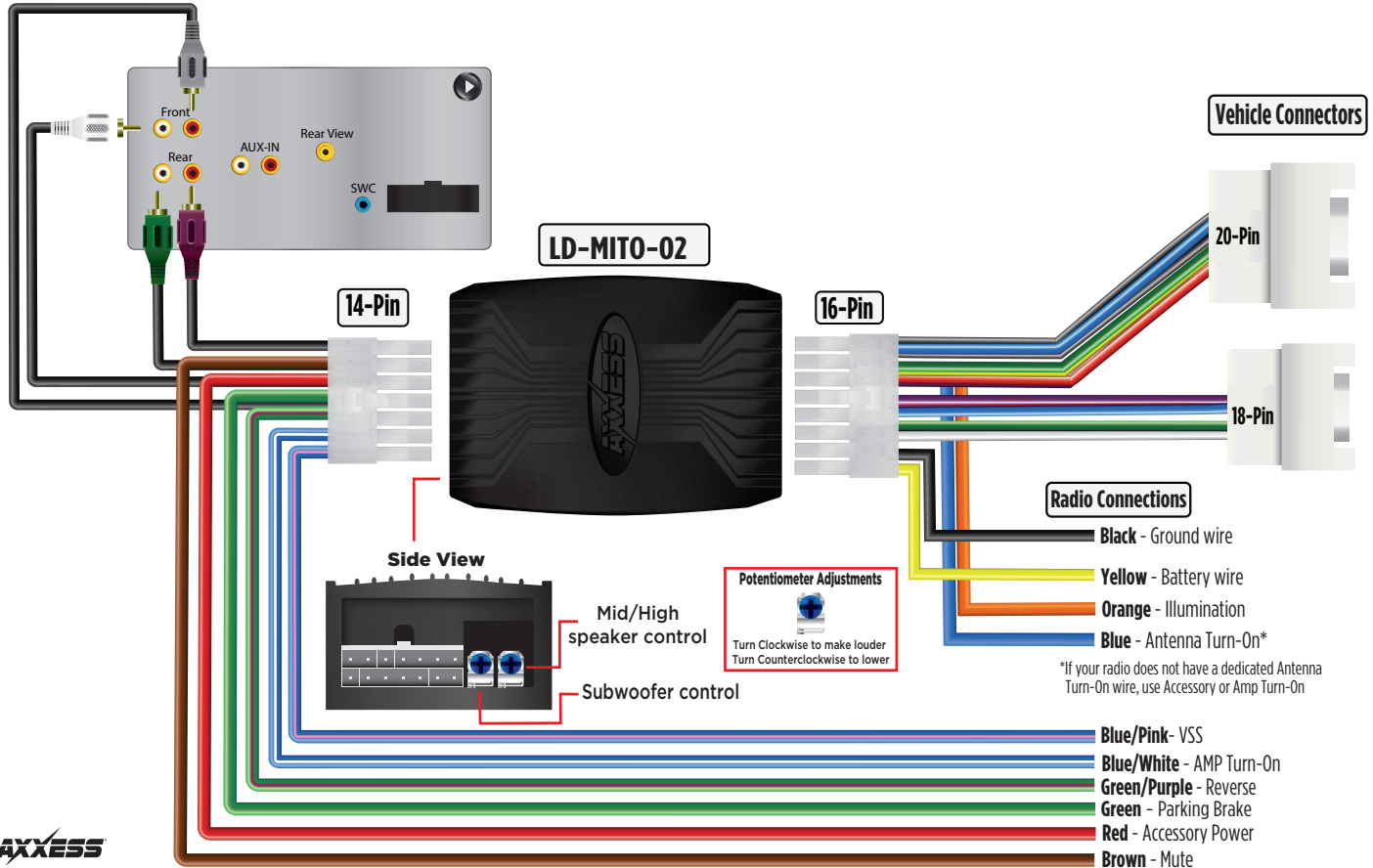

## INITIALIZING AND ADJUSTING THE AXTO-MI2

- Initialize the interface by turning the ignition on for 30 seconds, then turn the ignition back off, and on again.
- If the speakers are too loud, or not loud enough, you can adjust the output by following the steps below:
  1. Locate the two potentiometers on the side of the interface, see image at right.
  2. Using a small flat-blade screwdriver, turn the gain knob clockwise to make it louder, or counterclockwise to make it lower.

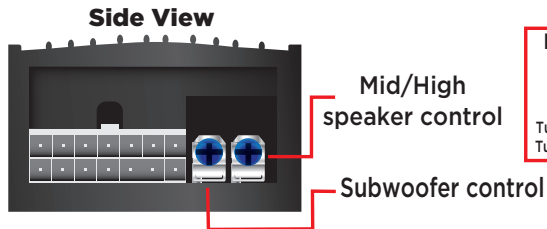

### Potentiometer Adjustments



Turn Clockwise to make louder  
Turn Counterclockwise to lower

Scan QR Code for AXSWC  
Connections/Programming





**Note:** If installing an AXSWC, the below harness modifications will need to be made.



Cut the **Brown/White** and **Brown/Yellow** wire(s).  
Tape off the **Brown/White** and **Brown/Yellow** wire(s) connected to the **16-Pin** connector.

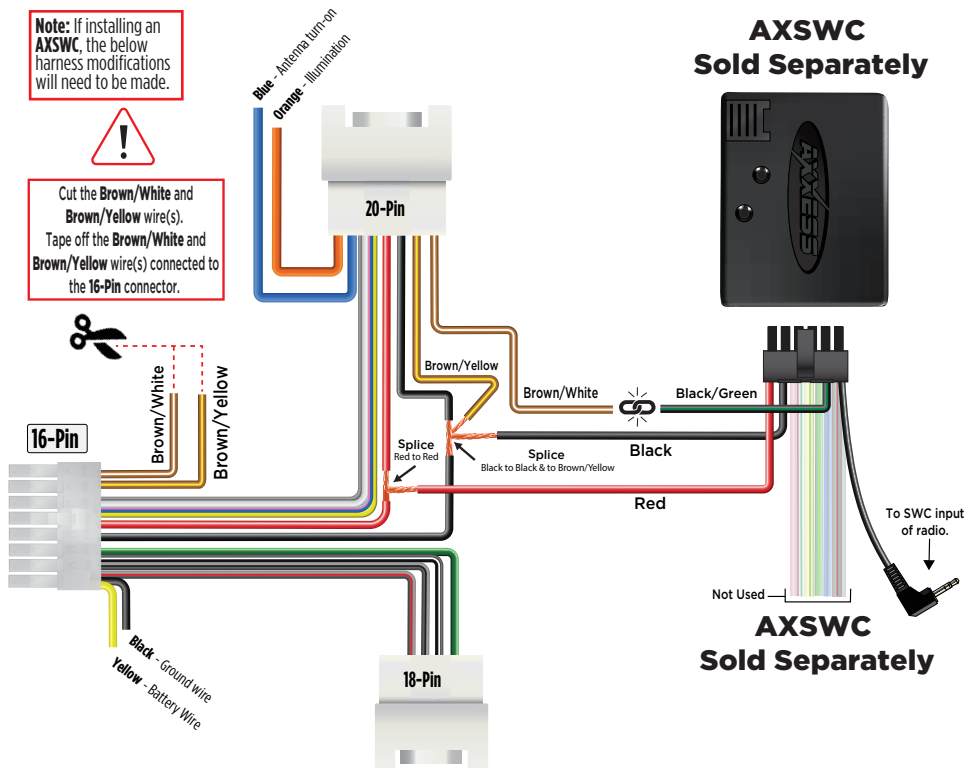

Having difficulties? We're here to help.



Contact our Tech Support line at:  
**386-257-1187**



Or via email at:  
techsupport@metra-autosound.com

### Tech Support Hours (Eastern Standard Time)

Monday - Friday: 9:00 AM - 7:00 PM

Saturday: 10:00 AM - 5:00 PM

Sunday: 10:00 AM - 4:00 PM



Metra recommends MECP  
certified technicians