

Universal 2 Sensor No Drill Parking Sensor Kit

Visit iBEAMUSA.com for more detailed information about the product and up-to-date vehicle specific applications.



Product Features

- 2 sensor parking solution
- No need to drill into the bumper
- Audible 3-zone alerts
- No additional control box needed
- Use for plastic bumpers only
- Easy to install

Part Components

A) 2 Sensors B) Wiring harness C) Accessories



TABLE OF CONTENTS

Technical Tip.....	2
Installation	3-5
Calibration	6
Wiring diagrams and specs	4-5

TOOLS REQUIRED

- Wire stripper
- Tape
- Digital Multi-meter
- Cutter
- Alcohol wipes/cleaning pads

Attention! When testing the aftermarket equipment, ensure that all factory equipment is connected before cycling the key to ignition.

TECHNICAL TIP

Installation

NOTE: This installation may require the removing of the bumper to get the proper sensor alignment.

1. Before removing of the bumper (if it is needed) iBEAM suggests measuring the placement of the sensors on the outside of the bumper with the provided ruler and painters tape.
2. Tape off the vertical mounting location 15-24 inches from the ground. Find the flattest surface possible. (Figure A.1)
3. Find the center of the bumper. Tape off two positions between 10 and 20 inches from the center on the left and right hand side. Again, find the flattest surface possible. (Figure A.2)
4. These tape markswill be used to indicate where on the opposite side the sensors will be mounted once the bumper is removed.
5. Remove the bumper. Each vehicle is different. Take care with removal, lay a cloth on the ground to protect the exterior paint from damage.

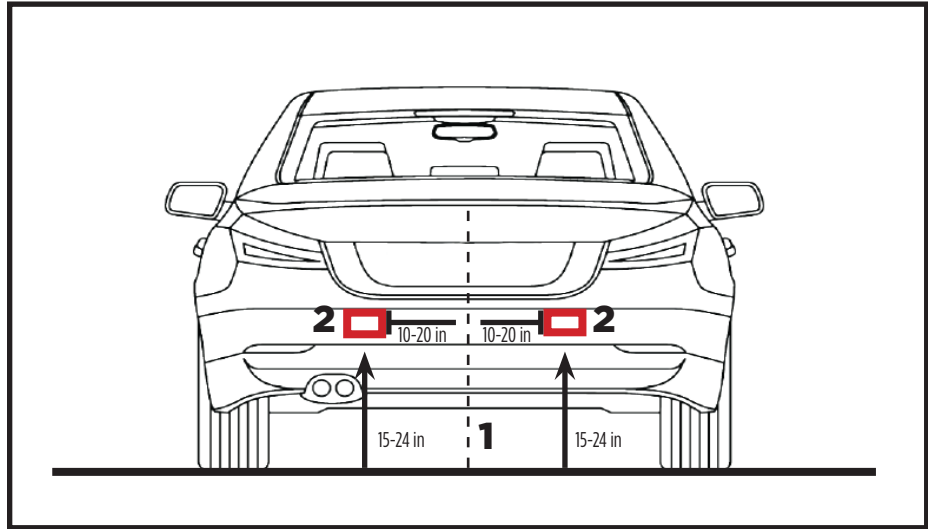

Figure A

INSTALLATION

Finding a reverse signal

1. Remove the tail light from the vehicle to allow access to the light bulbs wiring. (If help is needed, review the vehicles owners manual section on replacing the tail light bulbs.) **(Figure A)**
2. Find the wiring that connects to the reverse bulb. There is normally 2 wires. **(Figure B)** Strip the insulation to expose the copper wire.
3. Using a Digital Multi-meter on the DC Voltage setting, to verify the reverse wire. **(Figure C)**
4. Connect the wires from the TE-2SPK
 - Connect the **RED** wire to reverse, either found at the taillight or another source for reverse.
 - Connect the **BLACK** wire to chassis ground.

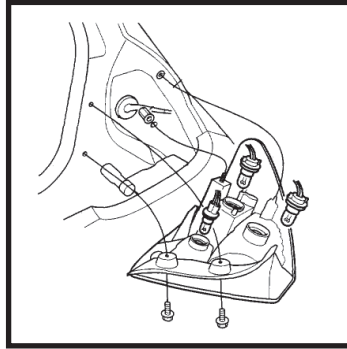

Figure A

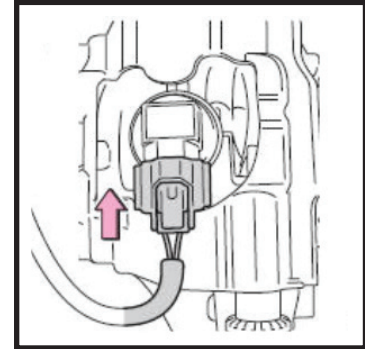

Figure B

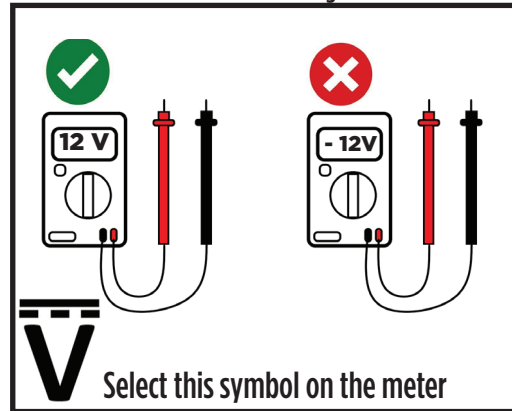

Figure C

INSTALLATION

Mounting of Sensors (Figure A)

NOTE: This installation may require the removing of the bumper to get the proper sensor alignment.

- Using the painters tape on the outside of the bumper as a guide, re-measure the desired sensor location on the inside of the bumper.
 - 10-20 inches from the bumper center
 - 15-24 inches from the ground

NOTE: Measurements do depend on the vehicles itself. There is a 4 inch tolerance on the measurements listed, but measurements can vary by vehicle. For example, a SUV may have a higher measurement from the ground.

- Clean the surface thoroughly where the sensors will be mounted on the inside of the bumper. Some dirt may cause the sensors to give false alerts.
- Remove the backing from the 3M double sided tape and use the provided adhesion promotor to assist in improving the adhesion to the bumper. Mount the sensors with the connector side mounting down towards the ground. Make sure the sensors are as straight as possible to each other and on the flattest surface possible on the bumper.

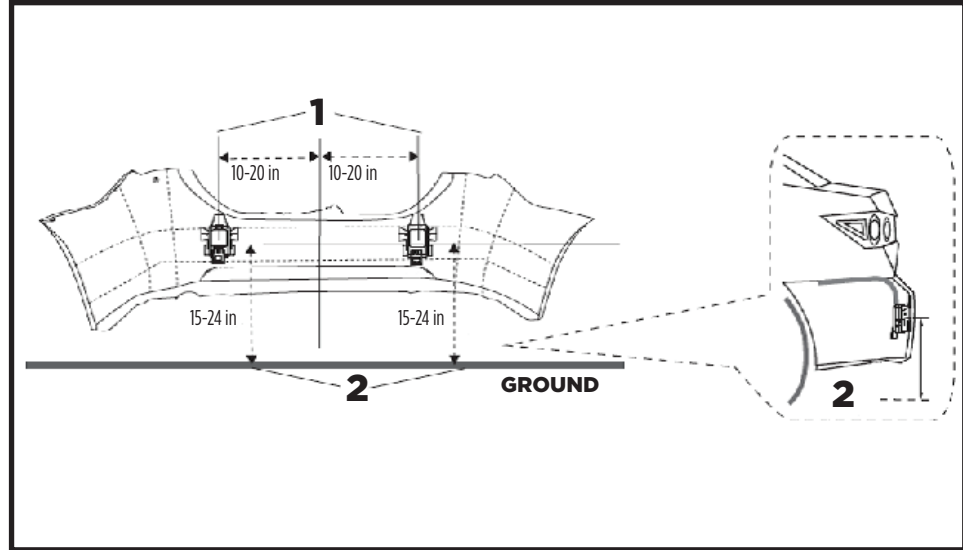

Figure A

INSTALLATION

Running the wiring

1. Carefully find a safe location to run the wires along the bumper or underside of the bumper on the vehicle. Use zip ties to secure the wiring to the vehicle. Please keep away from moving parts and anything that would cause too much heat near the wiring. (Figure A)
2. Find a suitable location to gain access to the inside of the vehicle.
3. Mount the Audible buzzer inside the vehicle in a good location that the driver will hear the alerts clearly. The wires may need to be extended if the location is desired near the front of the vehicle.
4. Remove the double sided tape and mount to a flat surface. If needed the adhesion promoter can be used here also. (Figure B)
5. Plug the buzzer in. Please keep the connector next to the buzzer available. This is for the calibration button which is used in the next step. This button does NOT need to remain plugged in after calibration is finished.

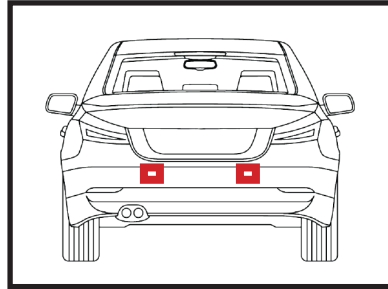

Figure A

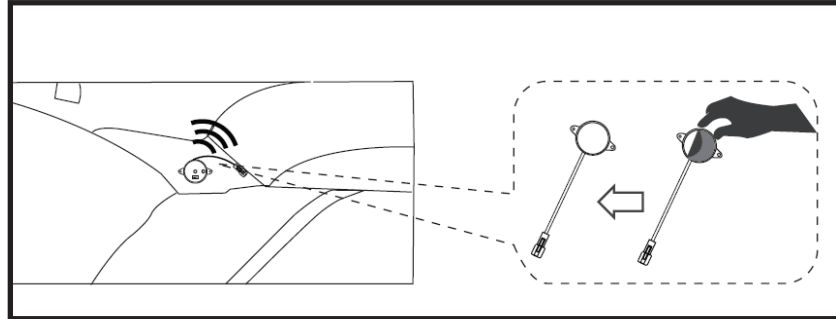

Figure B

CALIBRATION

Calibration

1. Complete the installation, put the bumper back in place, make sure power and ground are connected and the buzzer is plugged in. Connect the provided push button to the harness near the buzzer connection.
2. Check power up and make sure there are no moving object within 3 feet of the rear of the vehicle. (Figure A)
3. Press and hold the calibration button for more than 3 seconds to activate the parking sensor system. You should hear two continuous beeps. If not please repeat step 3.
4. Check function of the parking sensors.
5. There should be 3 zones of alerts
 - Level 1: 3.2 FT to 2 FT - slow beeping
 - Level 2: 2 FT to 1 FT - faster beeping
 - Level 3: less than 1 FT - constant beeping

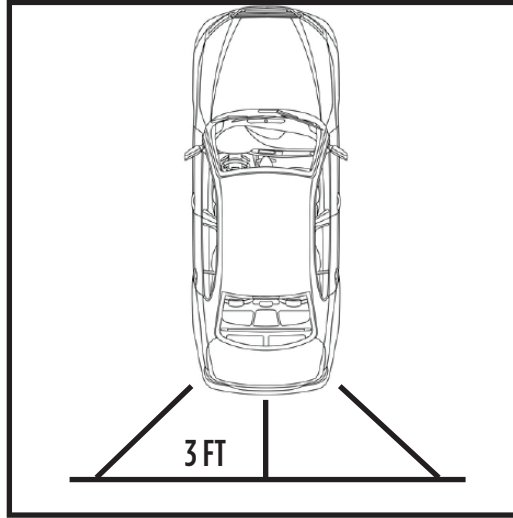

Figure A

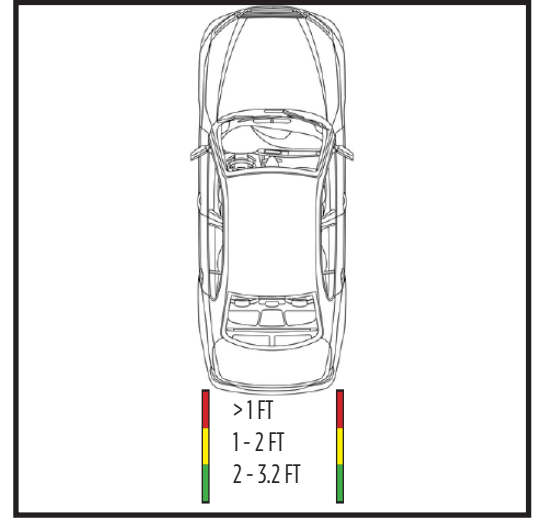
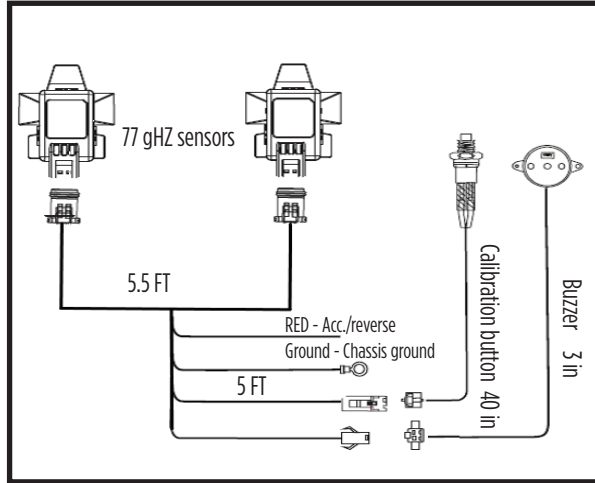

Figure A

WIRING DIAGRAM AND SPECS



Configuration	Dual sensors
Operating Freq.	77-81Ghz
Active condition	Speed < 10km/h and reverse gear
Field of view (Horz)	144 degrees
Alert range	3.2 FT max
Weight per sensor	16g
Dims per sensor	64.8 x 47.4 x 21.7 mm
Operation/storage temp	- 40 to 85 C
Power consumption	200 mA @ 12 VDC
Water resistant	IP67
Voltage range	8 - 18V



TE-2PSK
INSTALLATION INSTRUCTIONS
#iBEAMSAFETY



Having difficulties? We're here to help.



Contact our Tech Support line at:
386-257-1187



Or via email at:
techsupport@metra-autosound.com

Tech Support Hours (Eastern Standard Time)

Monday - Friday: 9:00 AM - 7:00 PM

Saturday: 10:00 AM - 7:00 PM

Sunday: 10:00 AM - 4:00 PM



KNOWLEDGE IS POWER

Enhance your installation and fabrication skills by enrolling in the most recognized and respected mobile electronics school in our industry. Log onto www.installerinstitute.com or call 800-354-6782 for more information and take steps toward a better tomorrow.



**Metra Recommends MECP
certified technicians**